



INDEX

SHAPES AND DIMENSIONS.....	1
PART NUMBER CODE	1
ELECTRICAL CHARACTERISTICS.....	2
REEL DIMENSIONS AND PACKAGING QUANTITY	3



Shielded SMT High Current Power Inductor AEC-Q200 standard compliance SPIM0302 series

■ SHAPES AND DIMENSIONS

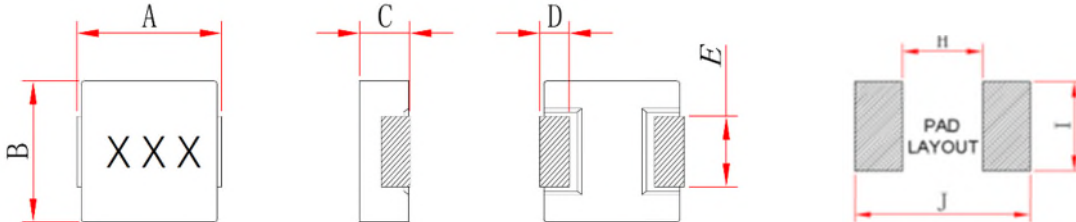

Unit: mm

Item	A	B	C	D	E	H	I	J
SPIM0302	3.4±0.2	3.0±0.2	1.8±0.2	0.7±0.3	1.3±0.2	1.2	2.0	4.2

Marking :

XXX = Inductance

Schematic :

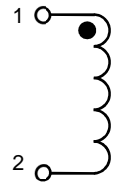

■ PART NUMBER CODE

SPIM **0302** - **1R0** **M** **A**
1 **2** **3** **4** **5**

1. Series Name
2. Size Code
3. Inductance(R=Decimal Point) Unit : μH ; 1R0 =1.0uH
4. Inductance tolerance: "M"±20%
5. Soldering : A=Lead Free



■ ELECTRICAL CHARACTERISTICS

1. Part Number and Characteristics Table

Part No.	Inductance L0 (uH)	DCR(mΩ)		Isat(A)		Irms(A)	
		Typ.	Max.	Typ.	Max.	Typ.	Max.
SPIM0302-R47MA	0.47	15.0	18.0	8.0	7.0	7.0	6.0
SPIM0302-1R0MA	1.0	32.0	36.0	5.5	5.0	5.0	4.0
SPIM0302-1R5MA	1.5	34.0	39.0	4.5	4.0	4.2	3.2
SPIM0302-2R2MA	2.2	59.0	69.0	4.0	3.0	2.9	2.5
SPIM0302-4R7MA	4.7	125.0	144.0	3.0	2.5	2.6	2.1
SPIM0302-100MA	10.0	250.0	260.0	1.4	1.2	1.2	1.0

Note 1: Referenced ambient temperature 25°C.

Note 2: Test Condition :1MHz ,1.0 Vrms.

Note 3: Isat (Typ): DC current (A) that will cause L0 to drop approximately 30%

Isat (Max): DC current (A) that will cause L0 to drop 30% Max

Irms (Typ): DC current (A) that will cause an approximate ΔT of 40°C

Irms (Max): DC current (A) that will cause an ΔT of 40°C Max

Note 4: Operating temperature range includes self-temperature rise.

Note 5: The rated current as listed is either the saturation current or the heating current depending on which value is lower.

2. Test equipments

2.1. L: Agilent E4980 Precision LCR meter(Upgraded version of Agilent HP4284A) With HP42841A Current Source.

2.2. DCR: Chroma16502 Milliohm Meter

2.3. IWT test: Chroma 19301(A).(Impulse winding test)

2.4. Operating temperature: -55°C to 125°C

* Equivalent measurement equipment may be used.



■ REEL DIMENSIONS AND PACKAGING QUANTITY

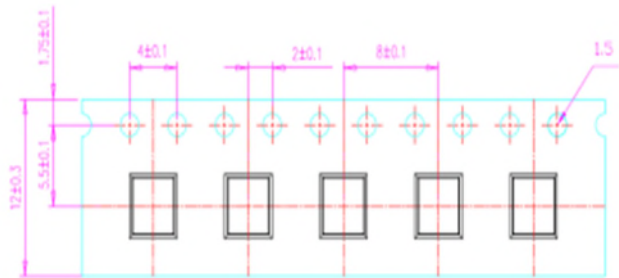
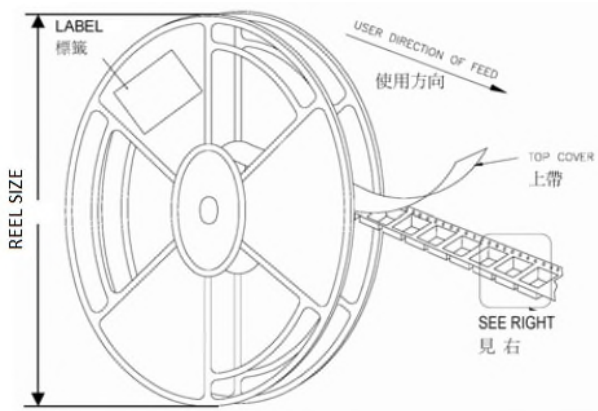

Unit: mm

TYPE	W	P	REEL SIZE	PCS / REEL
SPIM0302 series	12	8	330 mm (13")	3000