

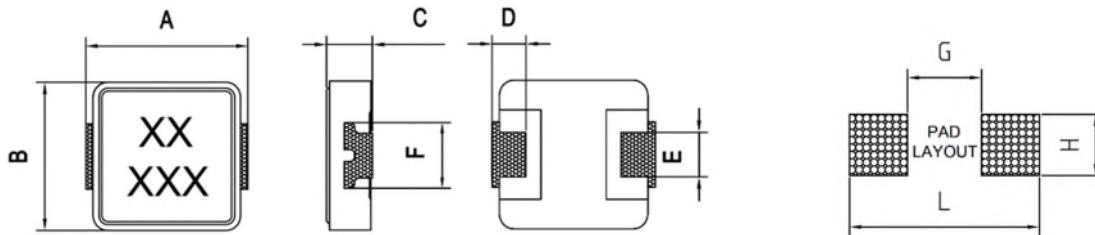

Shielded SMT High Current Power Inductor
Automotive reliability comply with AEC-Q200 grade 1
SPIM1004BT series

■ SHAPES AND DIMENSIONS



Unit: mm

Item	A	B	C Max	D	E	F	G	H	L
SPIM1004BT	11.0±0.5	10±0.3	4.0	2.3±0.3	3.0±0.5	4.4±0.3	5.4	4.5	12.4

Marking :

XX = MB
XXX = Inductance

Schematic :

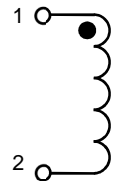

■ PART NUMBER CODE

SPIM **1004** **BT** - **1R0** **M** **A**
1 **2** **3** **4** **5** **6**

1. Series Name
2. Size Code
3. Material Code
4. Inductance(R=Decimal Point) Unit : μH ; 1R0 =1.0uH
5. Inductance tolerance: "M"±20%
6. Soldering : A=Lead Free



■ ELECTRICAL CHARACTERISTICS

1. Part Number and Characteristics Table

Part No.	Inductance L0 (uH)	DCR(mΩ)		Isat(A)		Irms(A)	
		Typ.	Max.	Typ.	Max.	Typ.	Max.
SPIM1004BT-2R2MA	2.2	7.09	9.0	35.0	26.0	16.0	12.0
SPIM1004BT-3R3MA	3.3	10.9	12.0	28.0	23.0	12.0	10.0
SPIM1004BT-4R7MA	4.7	15.5	16.5	22.0	17.0	11.0	9.5
SPIM1004BT-6R8MA	6.8	20.5	23.3	18.0	15.0	9.5	8.0
SPIM1004BT-100MA	10.0	28.4	36.5	14.0	12.0	8.0	6.8
SPIM1004BT-220MA	22.0	60.6	66.0	7.0	5.0	5.8	5.0
SPIM1004BT-330MA	33.0	93.2	98.0	6.5	4.8	4.5	4.1
SPIM1004BT-470MA	47.0	145.0	167.0	5.0	4.5	3.5	3.0

Note 1: Referenced ambient temperature 25°C.

Note 2: Test Condition :100kHz ,0.25 Vrms.

Note 3: Isat (Typ): DC current (A) that will cause L0 to drop approximately 30%

Isat (Max): DC current (A) that will cause L0 to drop 30% Max

Irms (Typ): DC current (A) that will cause an approximate ΔT of 40°C

Irms (Max): DC current (A) that will cause an ΔT of 40°C Max

Note 4: Operating temperature range includes self-temperature rise.

Note 5: The rated current as listed is either the saturation current or the heating current depending on which value is lower.

2. Test equipments

2.1. L: Wayne kerr 3260B LCR meter, Wayne kerr 3265B bias current source.

2.2. DCR: Chroma16502 Milliohm Meter

2.3. Operating temperature: -55°C to 125°C

* Equivalent measurement equipment may be used.



■ REEL DIMENSIONS AND PACKAGING QUANTITY

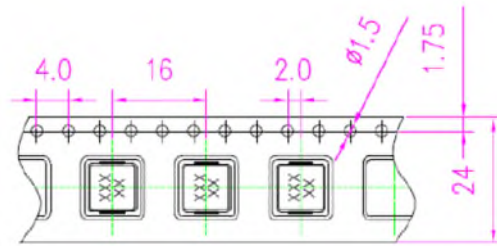
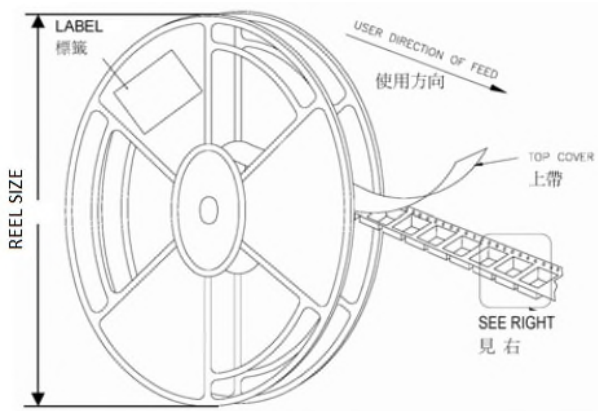

Unit: mm

TYPE	W	P	REEL SIZE	PCS / REEL
SPIM1004BT series	24	16	330 mm (13")	900