



SPECIFICATION FOR APPROVAL

INDEX

| | |
|--------------------------------------|-----|
| ➤ COVER PAGE | |
| ➤ INDEX | 0 |
| ➤ SHAPES & DIMENSION | 1 |
| ➤ PART NUMBER CODE | 2 |
| ➤ PRODUCT DETAIL | 3-4 |
| ➤ REEL DIMENSIONS | 5 |
| ➤ REEL PACKAGING QUANTITY | 5 |
| ➤ RELIABILITY & TEST CONDITION | 6-8 |
| ➤ SGS REPORT | |



PRODUCT DETAIL

| Electrical Characteristics | | | Test Instruments |
|----------------------------|----------|--|--|
| L | Page 3~4 | TEST FREQ: Page 3~4 TEST LEVEL: Page 3~4 Operating Temp.: -40°C~85°C | •L & Q : Agilent 4284A LCR meter •DCR : Milli-ohm meter. •SRF : Agilent E4991A RF Impedance Analyzer •HC-D3M TEMP. & HUMIDITY CHAMBER •Isat : The current when the inductance becomes 10% lower than its initial value. •Irms : The current when temperature of coil increases up to max $\Delta T=40^{\circ}\text{C}$. ($T_a=20^{\circ}\text{C}$) |
| DCR | Page 3~4 | | |
| Isat | Page 3~4 | | |
| Irms | Page 3~4 | | |

SHAPES AND DIMENSIONS :

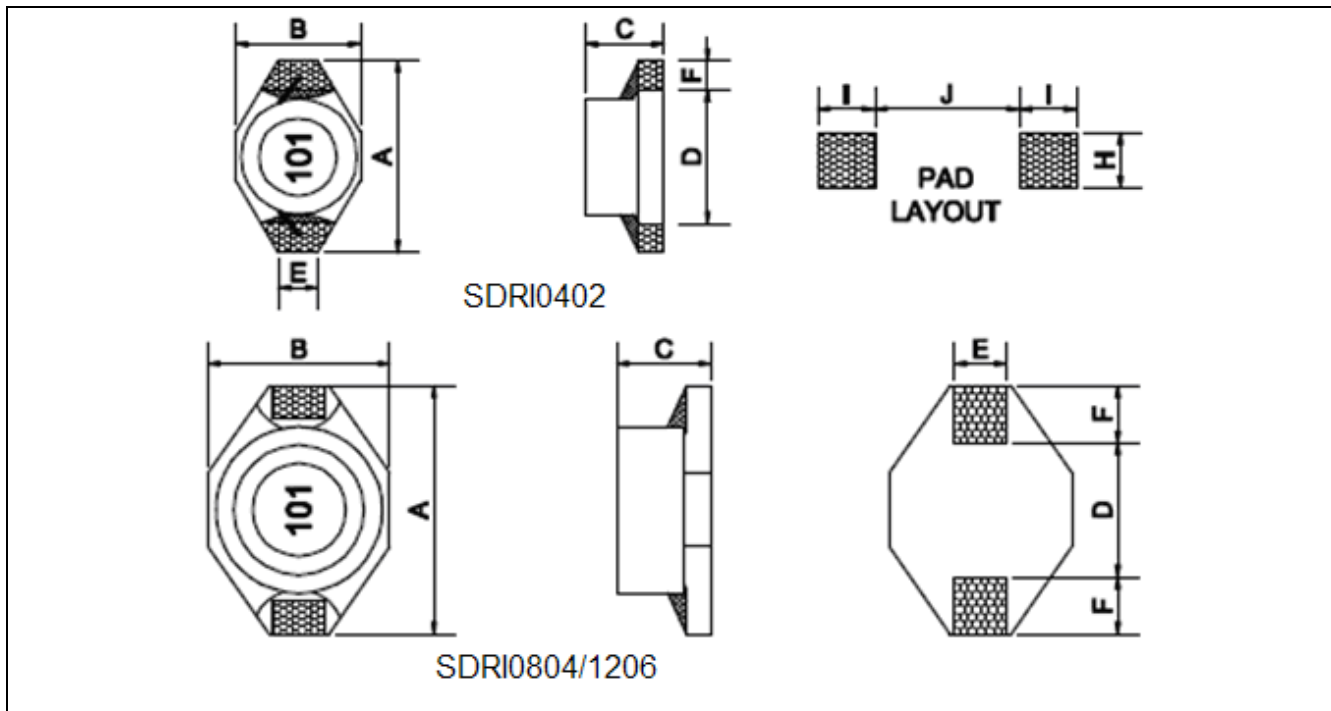

| P/N | Item /Spec.(mm) | | | | | | | | |
|----------|-----------------|--------|--------|-------|------|------|------|------|-------|
| | A(max) | B(max) | C(max) | D | E | F | H | I | J |
| SDRI0402 | 6.60 | 4.45 | 2.92 | 4.32 | 1.27 | 1.02 | 3.56 | 1.4 | 4.06 |
| SDRI0804 | 12.95 | 9.40 | 5.08 | 7.62 | 2.54 | 2.54 | 2.79 | 2.92 | 7.37 |
| SDRI1206 | 18.54 | 15.24 | 7.62 | 12.70 | 2.54 | 2.54 | 2.79 | 2.92 | 12.45 |

Marking : "XXX"



PART NUMBER CODE

| | | | | |
|-------------|-------------|------------|----------|----------|
| <u>SDRI</u> | <u>0402</u> | <u>2R2</u> | <u>N</u> | <u>A</u> |
| 1 | 2 | 3 | 4 | 5 |

1. Series Name
2. Size Code
3. Inductance (R=Decimal Point) Unit : μH .
4. Inductance tolerance : "M" \pm 20% ; "N" \pm 30%.
5. Soldering : A=Lead free



SHIELDED SMT POWER INDUCTORS

SDRI0402 TYPE

| Part No. | L (uH) | Q min | DCR max (Ω) | SRF ref (MHz) | I rms (A) |
|----------------|-----------|-------|----------------|------------------|--------------|
| SDRI0402-1R0NA | 1.0 | 30 | 0.040 | 250 | 3.0 |
| SDRI0402-1R5NA | 1.5 | 30 | 0.045 | 125 | 2.3 |
| SDRI0402-2R2NA | 2.2 | 40 | 0.050 | 120 | 1.8 |
| SDRI0402-3R3NA | 3.3 | 40 | 0.055 | 120 | 1.6 |
| SDRI0402-4R7NA | 4.7 | 40 | 0.060 | 105 | 1.4 |
| SDRI0402-6R8NA | 6.8 | 40 | 0.065 | 50 | 1.2 |
| SDRI0402-100MA | 10 | 40 | 0.075 | 38 | 1.0 |
| SDRI0402-150MA | 15 | 40 | 0.090 | 33 | 0.80 |
| SDRI0402-220MA | 22 | 40 | 0.11 | 25 | 0.70 |
| SDRI0402-330MA | 33 | 40 | 0.19 | 20 | 0.60 |
| SDRI0402-470MA | 47 | 40 | 0.23 | 20 | 0.50 |
| SDRI0402-680MA | 68 | 40 | 0.29 | 15 | 0.40 |
| SDRI0402-101MA | 100 | 40 | 0.48 | 10 | 0.30 |
| SDRI0402-151MA | 150 | 40 | 0.59 | 9.0 | 0.26 |
| SDRI0402-221MA | 220 | 40 | 0.90 | 6.0 | 0.22 |
| SDRI0402-331MA | 330 | 40 | 1.40 | 5.0 | 0.20 |
| SDRI0402-471MA | 470 | 40 | 1.80 | 4.0 | 0.19 |
| SDRI0402-681MA | 680 | 40 | 2.20 | 3.0 | 0.18 |
| SDRI0402-102MA | 1000 | 40 | 3.40 | 2.0 | 0.15 |
| SDRI0402-152MA | 1500 | 50 | 4.20 | 2.0 | 0.12 |
| SDRI0402-222MA | 2200 | 50 | 8.50 | 2.0 | 0.10 |
| SDRI0402-332MA | 3300 | 50 | 11.0 | 1.0 | 0.08 |
| SDRI0402-472MA | 4700 | 50 | 13.9 | 1.0 | 0.06 |
| SDRI0402-682MA | 6800 | 50 | 25.0 | 1.0 | 0.04 |
| SDRI0402-103MA | 10000 | 50 | 32.8 | 0.8 | 0.02 |

* Q tested Frequency : 1R0~100 200kHz 0.1V ; 150~103 100 kHz 0.1V



SHIELDED SMT POWER INDUCTORS
SDRI0804 / 1206 TYPE

| Part No. | L (uH) | DCR max (Ω) | SRF ref (MHz) | I sat (A) | I rms (A) |
|----------------|--------|-------------|---------------|-----------|-----------|
| SDRI0804-1R0NA | 1.0 | 0.021 | 140 | 5.6 | 5.0 |
| SDRI0804-1R5NA | 1.5 | 0.022 | 120 | 5.2 | 4.5 |
| SDRI0804-2R2NA | 2.2 | 0.032 | 80 | 5.0 | 3.8 |
| SDRI0804-3R3NA | 3.3 | 0.039 | 70 | 3.9 | 3.3 |
| SDRI0804-4R7NA | 4.7 | 0.054 | 40 | 3.2 | 2.7 |
| SDRI0804-6R8NA | 6.8 | 0.075 | 38 | 2.8 | 2.2 |
| SDRI0804-100MA | 10 | 0.101 | 35 | 2.4 | 2.0 |
| SDRI0804-150MA | 15 | 0.150 | 25 | 2.0 | 1.5 |
| SDRI0804-220MA | 22 | 0.207 | 19 | 1.6 | 1.3 |
| SDRI0804-330MA | 33 | 0.334 | 15 | 1.4 | 1.1 |
| SDRI0804-470MA | 47 | 0.472 | 13 | 1.0 | 0.8 |

| | | | | | |
|----------------|------|-------|-----|------|------|
| SDRI1206-100MA | 10 | 0.040 | 30 | 8.0 | 3.9 |
| SDRI1206-150MA | 15 | 0.048 | 20 | 7.0 | 3.4 |
| SDRI1206-220MA | 22 | 0.059 | 18 | 6.0 | 3.1 |
| SDRI1206-330MA | 33 | 0.075 | 14 | 5.0 | 2.8 |
| SDRI1206-470MA | 47 | 0.097 | 10 | 4.0 | 2.4 |
| SDRI1206-680MA | 68 | 0.138 | 9.0 | 3.0 | 2.0 |
| SDRI1206-101MA | 100 | 0.207 | 7.0 | 2.4 | 1.7 |
| SDRI1206-151MA | 150 | 0.293 | 6.0 | 2.1 | 1.3 |
| SDRI1206-221MA | 220 | 0.470 | 5.0 | 1.9 | 1.1 |
| SDRI1206-331MA | 330 | 0.780 | 4.0 | 1.1 | 0.86 |
| SDRI1206-471MA | 470 | 1.08 | 3.0 | 1.1 | 0.73 |
| SDRI1206-681MA | 680 | 1.40 | 2.5 | 0.96 | 0.64 |
| SDRI1206-102MA | 1000 | 2.01 | 2.0 | 0.80 | 0.53 |



REEL DIMENSIONS :

Unit: mm

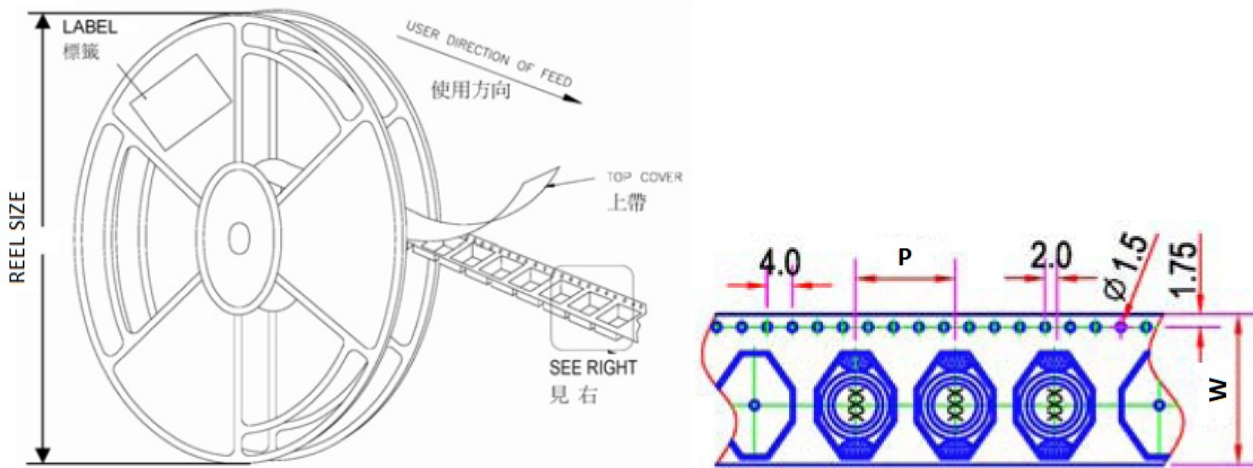

REEL PACKAGING QUANTITY

| TYPE | W | P | REEL SIZE | PCS / REEL |
|-----------------|----|----|--------------|------------|
| SDRI0402 | 16 | 8 | 330 mm (13") | 2000 |
| SDRI0804 | 24 | 16 | 330 mm (13") | 500 |
| SDRI1206 | 32 | 20 | 330 mm (13") | 400 |



RELIABILITY AND TEST CONDITION

Environmental tests conditions (SMD wire wound Inductor)

| Item (項目) | Required Characteristics (要求) | Test Method/Condition (測試方法) |
|---|--|---|
| <p>High temperature Storage test</p> <p>Reference documents: MIL-STD-202G Method 108A</p> <p>高溫儲存試驗</p> | <p>1.No case deformation or change in appearance. 2.$\Delta L/L \leq 10\%$ or 15% 3.$\Delta DCR/DCR \leq 10\%$</p> <p>N : The High temperature, depend on the spec. N : 高溫設定，依據產品規格設定</p> <p>1.無明顯的外觀缺陷 2.感值變化不超過 10% 或者 15% 3.直流電阻變化不超過 10%</p> | <p>Temperature: $N \pm 2^\circ\text{C}$ Time : 96 ± 2 hours Tested not less than 1 hour, nor more than 2 hours at room temperature.</p> <p>溫度: $N \pm 2^\circ\text{C}$, 時間: 96 ± 2 小時 樣品在室溫下放置 1 小時, 不超過 2 小時必須測試.</p> |
| <p>Low temperature Storage test</p> <p>Reference documents: IEC 68-2-1A 6.1 6.2</p> <p>低溫儲存試驗</p> | <p>1.No case deformation or change in appearance. 2.$\Delta L/L \leq 10\%$ or 15% 3.$\Delta DCR/DCR \leq 10\%$</p> <p>M : The Low temperature, depend on the spec. M : 低溫設定，依據產品規格設定</p> <p>1.無明顯的外觀缺陷 2.感值變化不超過 10% 或者 15% 3.直流電阻變化不超過 10%</p> | <p>Temperature: $M \pm 2^\circ\text{C}$ Time : 96 ± 2 hours Tested not less than 1 hour, nor more than 2 hours at room temperature.</p> <p>溫度: $M \pm 2^\circ\text{C}$, 時間: 96 ± 2 小時 樣品在室溫下放置 1 小時, 不超過 2 小時必須測試.</p> |
| <p>Humidity test Reference</p> <p>documents: MIL-STD-202G Method 103B</p> <p>濕度測試</p> | <p>1.No case deformation or change in appearance. 2.$\Delta L/L \leq 10\%$ or 15% 3.$\Delta DCR/DCR \leq 10\%$</p> <p>1.無明顯的外觀缺陷 2.感值變化不超過 10% 或者 15% 3.直流電阻變化不超過 10%</p> | <p>Temperature: $40 \pm 2^\circ\text{C}$, Humidity: $93 \pm 3\% \text{RH}$ Time : 96 ± 2 hours Tested not less than 1 hour, nor more than 2 hours at room temperature.</p> <p>溫度: $40 \pm 2^\circ\text{C}$, 濕度: $93 \pm 3\% \text{RH}$ 時間 : 96 ± 2 hours 樣品在室溫下放置 1 小時, 不超過 2 小時必須測試.</p> |
| <p>Thermal shock test</p> <p>Reference documents: MIL-STD-202G Method 107G</p> <p>熱衝擊測試</p> | <p>1.No case deformation or change in appearance. 2.$\Delta L/L \leq 10\%$ or 15% 3.$\Delta DCR/DCR \leq 10\%$</p> <p>N : The High temperature, depend on the spec. M : The Low temperature, depend on the spec.</p> <p>For T: weight $\leq 28\text{g}$: 15Min; $28\text{g} \leq \text{weight} \leq 136\text{g}$: 30Min</p> <p>1.無明顯的外觀缺陷 2.感值變化小於 10% 或者 15% 3.直流電阻變化小於 10%</p> | <p>First $M^\circ\text{C}$ for T time, next $N^\circ\text{C}$ for T time as 1 cycle. Go through 20 cycles.</p> <p>從 $M^\circ\text{C}$ 作用 T 分鐘, 然後溫度衝擊到 $N^\circ\text{C}$ 作用 T 分鐘, 作為一個循環, 共作用 20 次.</p> |

Physical characteristic tests conditions (SMD wire wound Inductor)

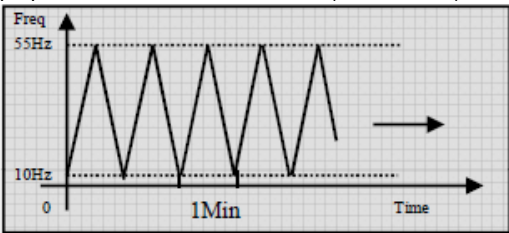
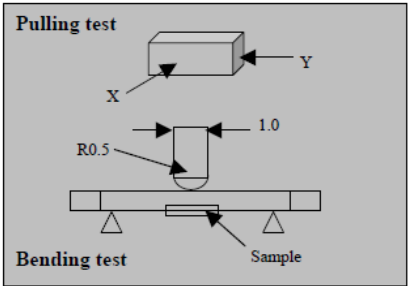
| Item (項目) | Required Characteristics (要求) | Test Method/Condition (測試方法) |
|---|--|---|
| Solderability test Reference documents: MIL-STD-202G Method 208H IPC J-STD-002B 可焊性測試 | Terminals area must have 95% min. Solder coverage 端子必須有 95%以上著錫 | <ul style="list-style-type: none"> ● Dip pads in flux then dip in solder pot at 245±5°C for 5 second. ● Solder: lead free ● Flux: rosin flux ● 端子侵入著焊劑，然後侵入 245±5°C 錫爐中 5 秒 ● 焊料：無鉛焊料 ● 助焊劑：松香助焊劑 |
| Heat endurance of Reflow soldering Reference documents: IPC J-STD-020D 過再流焊測試 | <ul style="list-style-type: none"> ● No case deformation or change in appearance. ● $\Delta L/L \leq 10\%$ or 15% ● $\Delta DCR/DCR \leq 10\%$ ● 無明顯的外觀缺陷 ● 感值變化不超過 10% 或者 15% ● 直流電阻變化不超過 10% | <ul style="list-style-type: none"> ● Refer to the next page reflow curve Go through 3 times ● The peak temperature : 260+/-5°C ● 參照下頁回流焊曲線過三次 ● 峰值溫度為: 260+/-5°C |
| Vibration test Reference documents: MIL-STD-202G Method 201A 振動測試 | 1.No case deformation or change in appearance. 2.No short and no open. 1.無明顯的外觀缺陷 2.無短路開路異常 | Apply frequency 10~55Hz. 1.5mm amplitude in each of perpendicular direction for 2 hours.(total 6 hours)  用 10~55Hz 振動頻率 1.5mm 振幅沿 X,Y,Z 方向各振動 2 小時.(共 6 小時) |
| Drop test Reference documents: MIL-STD-202G Method 203C 落下試驗 | 1.No case deformation or change in appearance. 2.No short and no open. 1.無明顯的外觀缺陷 2.無短路開路異常 | Packaged & Drop down from 1m with 981m/s ² (100G) attitude In 1 angle 1 ridges & 2 surfaces orientations. 將產品包裝後從 1 米高度自然落下至試驗板上 1 角 1 稜 2 面 |
| Terminal strength push test Reference documents: JIS C 5321:1997 端子強度試驗 | Pulling test: DEFINE: A: sectional area of terminal $0.5\text{mm}^2 < A \leq 1.2\text{mm}^2$; force >2kgf ; time : 10sec $1.2\text{mm}^2 < A$; force >4kgf ; time: 10sec Bending test: Soldering the products on PCB, after the pulling test and bending test ,terminal should not pull off 推力測試 定義: A: 焊接端子截面積 $0.5\text{mm}^2 < A \leq 1.2\text{mm}^2$; 推力 >2kgf ; 時間: 10sec $1.2\text{mm}^2 < A$; 推力 >4kgf ; 時間: 10sec 彎折測試: 將產品焊於PCB上,分別經過推力測試和彎折測試後,端子不會發生松脫 | Bend the testing PCB at middle point, the deflection shall be 2mm  將 PCB 對中彎折,到達撓度 2mm |
| Resistance to solvent test Reference documents: IEC 68-2-45:1993 耐溶劑性試驗 | No case deformation or change in appearance, or obliteration of marking 無外觀破壞及標記破損 | To dip parts into IPA solvent for 5±0.5Min, then drying them at room temp for 5Min,at last ,to brushing making 10 times. 在 IPA 溶劑中浸泡 5±0.5 分鐘,室溫下乾燥 5 分鐘,然後擦拭 10 次。 |



RELIABILITY TEST CONDITIONS WIRE WOUND CHIP INDUCTORS TYPE

| Item (項目) | Required Characteristics(要求) | Test Method / Condition (測試方法) |
|--|---|---|
| Electronic characteristic test of major products 主要產品電特性測試 | Refer to catalogue of specific products 參照具體產品目錄頁 | Refer to catalogue of specific products 參照具體產品目錄頁書 |
| Overload test Reference documents: JIS C5311-6.13 過負荷試驗 | <ul style="list-style-type: none"> ● During the test no smoke, no peculiar, smell, no fire ● The characteristic is normal after test ● 試驗過程中無冒煙,異味,著火等, ● 試驗後產品特性正常 | Apply twice as rated current for 5 minutes. (It's not application to some special design) 通兩倍額定電流 5 分鐘 (部分特殊設計產品不適用) |

Curve of Heat endurance of Reflow soldering test

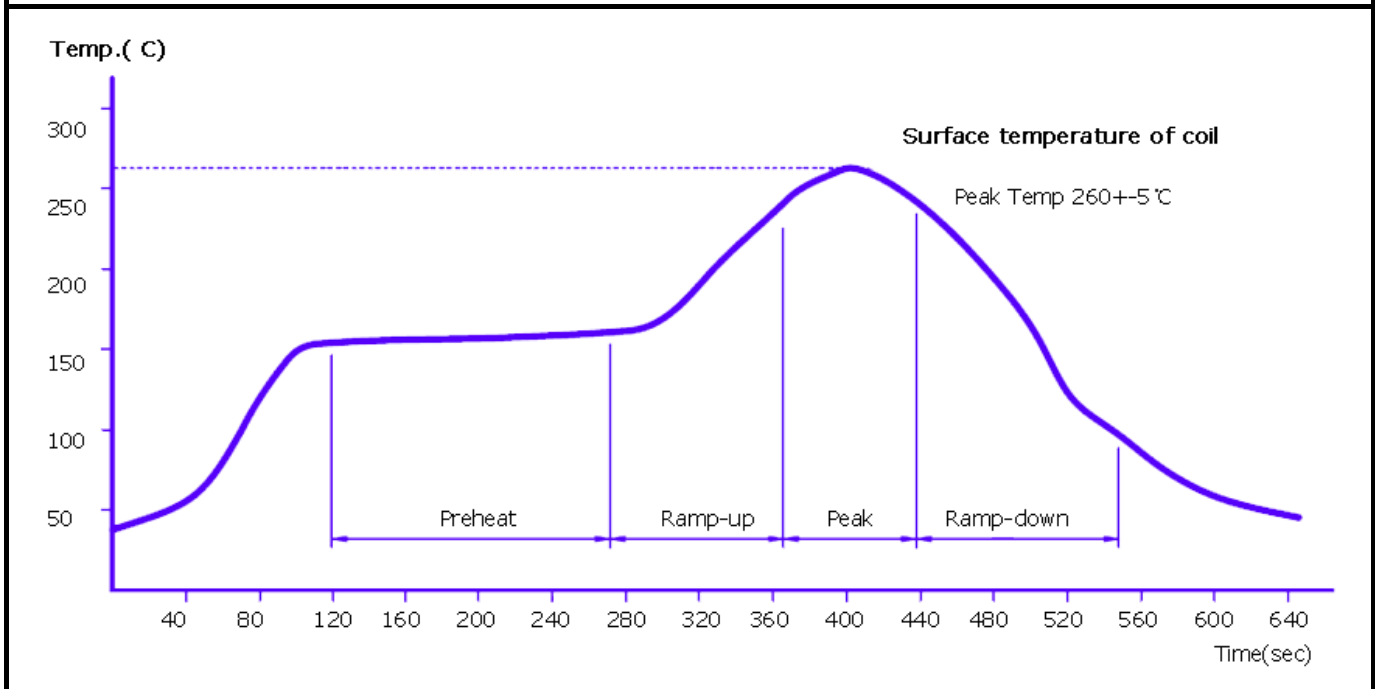

1. This peak temperature only applicable to some special parts. The operating parameter may very according to the part type.
2. A test is made under the conditions mentioned above. And it is left 1 hour in the normal temperature and humidity. After that, no mechanical and electrical defeat should be found out.
3. The reflow condition is according to the machine used by our company.

NOTE : Above specifications are only for reference, follow confirmation documents for the specific test conditions.