



INDEX

SHAPES AND DIMENSIONS..... 1

PART NUMBER CODE 2

ELECTRICAL CHARACTERISTICS 2

REEL DIMENSIONS AND PACKAGING QUANTITY 5



Shielded SMT Power Inductor STH2012-W Series

■ SHAPES AND DIMENSIONS

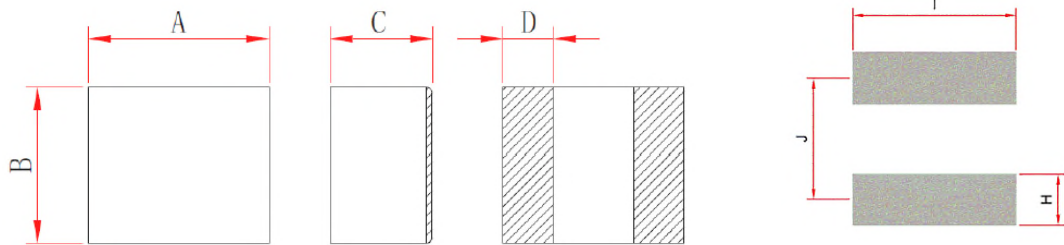

Unit: mm

Recommend PAD Layout

P/N	A	B	C	D	H	I	J
STH201208W	2.00±0.2	1.20±0.2	0.80Max	0.75±0.2	0.80	1.30	1.30
STH201210W	2.00±0.2	1.20±0.2	1.00 Max	0.75±0.2	0.80	1.30	1.30

Marking :

No marking

Equivalent circuit

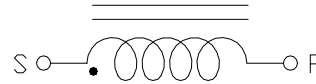



■ PART NUMBER CODE

STH 201208 W - 1R0 M A
1 2 3 4 5 6

1. Series Name
2. Size Code
3. Type Code
4. Inductance(R=Decimal Point) Unit : μH ; 1R0 =1.0 μH
5. Inductance tolerance: "M" $\pm 20\%$
6. Soldering : A=Lead Free

■ ELECTRICAL CHARACTERISTICS

1. Test equipments

- 1.1. L : WK3260,WK3265B,WK6500,WK6565 LCR Meter.
- 1.2. DCR: Chroma16502, Hioki 3545 Milliohm Meter.
- 1.3. Operating temperature range from -55°C to 125°C (includes self-temperature rise)

The part temperature (ambient + temp rise) should not exceed 125°C under the worst case operating condition. Circuit design, component, PCB trace size and thickness airflow and other cooling provisions all could affect the part temperature. Part temperature should be verified in the end application.

* Equivalent measurement equipment may be used.



2. Part Number and Characteristics Table

Part No.	Inductance L0 (uH)	Tolerance (±%)	DCR(mΩ)	Isat(A)		Irms(A)	
			Max.	Max.	Typ.	Max.	Typ.
STH201208W-R11MA	0.11	20	12	9.0	9.5	6.5	7.0
STH201208W-R24MA	0.24	20	23	6.0	6.5	5.9	6.5
STH201208W-R33MA	0.33	20	45	4.8	5.2	4.0	4.3
STH201208W-R47MA	0.47	20	50	4.6	5.0	3.3	3.5
STH201208W-R68MA	0.68	20	60	3.7	4.2	3.3	3.7
STH201208W-1R0MA	1.0	20	70	3.5	4.0	2.9	3.3
STH201208W-1R5MA	1.5	20	135	2.5	3.0	1.9	2.2
STH201208W-2R2MA	2.2	20	185	2.3	2.6	1.8	2.2
STH201208W-3R3MA	3.3	20	300	1.6	1.9	1.5	1.8
STH201208W-4R7MA	4.7	20	325	1.4	1.6	1.5	1.7

Note:

- All test data is referenced to 25°C ambient.
- Test Condition: 1MHz, 1.0 Vrms.
- Isat (Typ): DC current (A) that will cause L0 to drop approximately 30%.
- Irms (Typ): DC current (A) that will cause an approximate ΔT of 40°C.



Part No.	Inductance L0 (uH)	Tolerance (±%)	DCR(mΩ)	Isat(A)		Irms(A)	
			Max.	Max.	Typ.	Max.	Typ.
STH201210W-R10MA	0.10	20	13	8.0	8.5	7.0	7.5
STH201210W-R22MA	0.22	20	22	6.8	7.3	6.5	7.1
STH201210W-R24MA	0.24	20	23	6.7	7.2	6.4	7.0
STH201210W-R33MA	0.33	20	32	6.0	6.5	5.0	5.5
STH201210W-R47MA	0.47	20	36	5.0	5.5	4.3	4.7
STH201210W-R68MA	0.68	20	43	4.5	5.0	4.0	4.3
STH201210W-1R0MA	1.0	20	63	3.5	4.0	3.5	3.9
STH201210W-1R5MA	1.5	20	85	2.7	3.2	2.6	3.1
STH201210W-2R2MA	2.2	20	150	2.4	2.7	1.7	2.0
STH201210W-6R8MA	6.8	20	520	1.2	1.45	1.3	1.5
STH201210W-100MA	10.0	20	660	1.0	1.2	0.9	1.0

Note:

- All test data is referenced to 25°C ambient.
- Test Condition: 1MHz, 1.0 Vrms.
- Isat (Typ): DC current (A) that will cause L0 to drop approximately 30%.
- Irms (Typ): DC current (A) that will cause an approximate ΔT of 40°C.



REEL DIMENSIONS AND PACKAGING QUANTITY

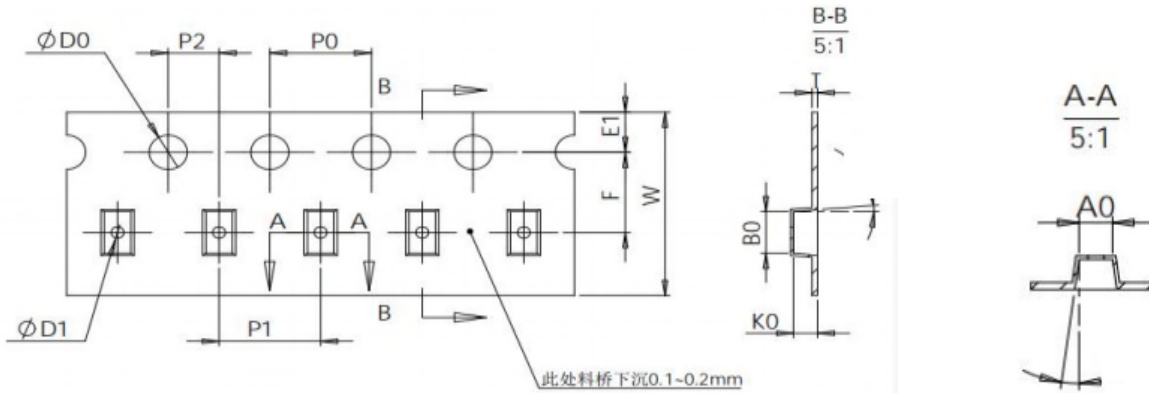

Tape dimensions (mm)												
P/N	W	P0	P1	P2	D	D1	T	A0	B0	K0	E1	F
STH201208W	8±0.3	4±0.1	4±0.1	2±0.1	1.5+0.1/-0	1.0	0.23±0.05	1.50±0.05	2.35±0.05	1.00±0.05	1.75±0.1	3.50±0.1
STH201210W	8±0.3	4±0.1	4±0.1	2±0.1	1.5+0.1/-0	1.0	0.23±0.05	1.50±0.05	2.35±0.05	1.20±0.05	1.75±0.1	3.50±0.1

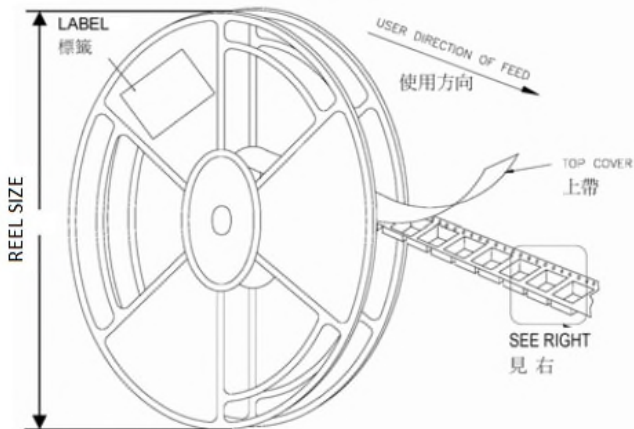

Unit: mm

TYPE	W	P	REEL SIZE	PCS / REEL
STH201208W	8	4	178 mm	3000
STH201210W	8	4	178 mm	3000