



# SPECIFICATION FOR APPROVAL

## INDEX

➤ COVER PAGE	
➤ INDEX .....	0
➤ SHAPES & DIMENSION .....	1
➤ PART NUMBER CODE .....	2
➤ PRODUCT DETAIL .....	3
➤ REEL DIMENSIONS .....	4
➤ REEL PACKAGING QUANTITY .....	4
➤ RELIABILITY & TEST CONDITION .....	5-7
➤ SGS REPORT	



## PRODUCT DETAIL

Electrical Characteristics			Test Instruments
L	Page.3	<b>TEST FREQ:</b> 100KHz  <b>TEST LEVEL:</b> 0.1V  <b>Ope.Temp.:</b> -30°C~105°C	<ul style="list-style-type: none"> <li>•L tested by Agilent 4284A LCR meter.</li> <li>• DCR tested by Milli-ohm meter.</li> <li>• Electrical specifications at 25°C.</li> <li>•Isat : The current when the inductance becomes 25% (5D28R and 104R are 35%) lower than its initial value.</li> <li>•Irms : The current when temperature of coil increases up to max <math>\Delta T=40^{\circ}\text{C}</math>. (<math>T_a=20^{\circ}\text{C}</math>)</li> </ul>
DCR	Page.3		
Isat	Page.3		
Irms	Page.3		

## SHAPES AND DIMENSIONS :

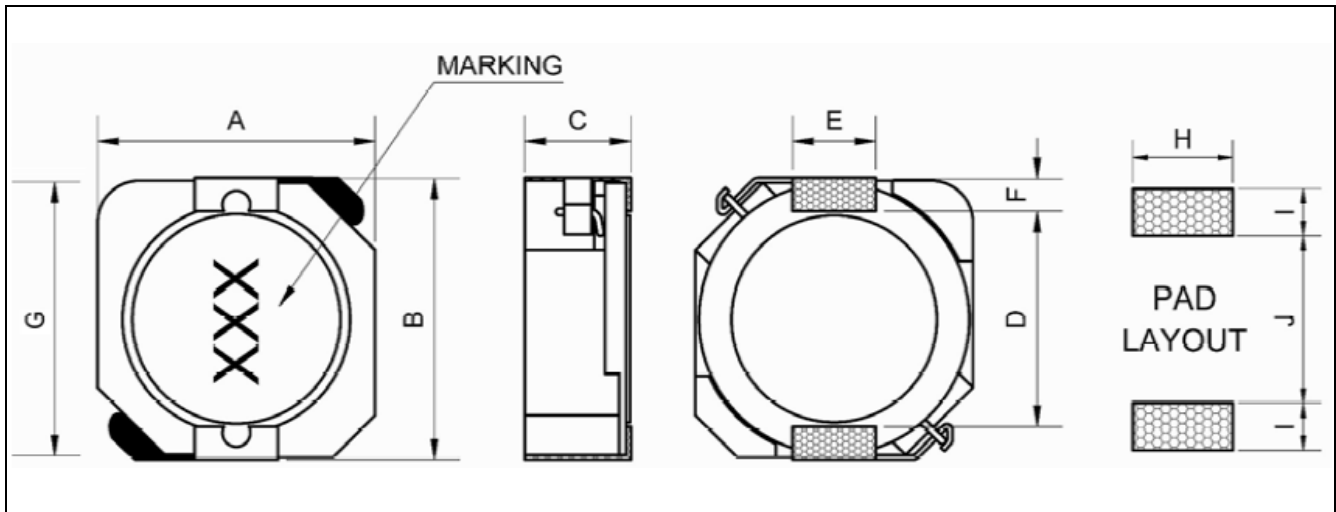

P/N	Item /Spec.(mm)									
	A max	B max	C max	D	E	F	G	H	I	J
SDRH5D28R	6.2	6.3	3.0	4.7	2.0	0.6	6.45	2.6	1.0	4.6
SDRH103R	10.3	10.4	3.0	7.7	3.0	1.2	10.55	3.6	1.7	7.3
SDRH104R	10.3	10.4	4.0	7.7	3.0	1.2	10.55	3.6	1.7	7.3
SDRH105R	10.3	10.4	5.0	7.7	3.0	1.2	10.55	3.6	1.7	7.3

Marking : "XXX"



## PART NUMBER CODE

<u>SDRH</u>	<u>5D28R</u>	<u>100</u>	<u>N</u>	<u>A</u>
1	2	3	4	5

1. Series Name
2. Size Code
3. Inductance (R=Decimal Point) Unit :  $\mu\text{H}$
4. Inductance tolerance : "N"  $\pm 30\%$ .
5. Soldering : A=Lead free



**SHIELDED SMT POWER INDUCTORS**  
**SDRH 5D28R / 103R / 104R / 105R TYPE**

Part No.	L ( $\mu$ H)	DC Resistance (m $\Omega$ ) max				I rms (Amp) max				I sat (Amp) max			
		5D28R	103R	104R	105R	5D28R	103R	104R	105R	5D28R	103R	104R	105R
R80N	0.8		5.7		4.3		6.50		7.50		9.0		12.00
1R5N	1.5		11.0	8.1	5.8		4.20	6.5	7.00		7.0	10	9.00
2R2N	2.2		16.9		7.2		4.05		6.30		5.8		7.50
2R5N	2.5	17.6		10		2.60		6.1		2.60		7.5	
3R3N	3.3	20.3	21.0		10.4	2.30	3.80		5.75	2.30	4.6		6.00
3R8N	3.8			13				5.5				6.0	
4R0N	4.0	27.0				2.10				2.10			
4R7N	4.7		30.0		12.3		3.30		4.75		4.0		5.20
5R0N	5.0	31.1				1.85				1.85			
5R2N	5.2			22				5.4				5.5	
6R0N	6.0	41.9				1.70				1.70			
6R8N	6.8		35.0		18.0		3.15		4.10		3.2		4.20
7R0N	7.0			27				4.5				4.8	
8R0N	8.0	49.9				1.50				1.50			
8R2N	8.2		50.0		20.0		2.50		4.00		3.0		3.80
100N	10	54.0	58.1	35	25.8	1.30	2.40	3.8	3.75	1.30	2.7	4.4	3.45
120N	12	71.6	72.1		32.0	1.20	2.10		3.00	1.20	2.4		3.40
150N	15	82.4	86.5	50	40.0	1.10	2.05	3.1	2.65	1.10	2.2	3.6	2.83
180N	18	101.5	116.1		46.0	1.05	1.50		2.20	1.05	2.0		2.62
220N	22	119.0	143.0	73	58.5	0.95	1.20	2.5	1.80	0.95	1.8	2.9	2.44
270N	27	146.0	175.9		65.4	0.85	1.15		1.70	0.85	1.65		2.24
330N	33	182.5	202.0	93	81.4	0.76	1.10	2.2	1.65	0.76	1.48	2.3	1.88
390N	39	209.5	268.9		103.1	0.68	1.00		1.60	0.68	1.35		1.70
470N	47	229.5	299.0	128	122.1	0.60	0.90	1.9	1.50	0.60	1.20	2.1	1.56
560N	56	305.0	325.0		144.8	0.55	0.78		1.45	0.55	1.15		1.39
680N	68	351.0	429.0	213	193.0	0.48	0.68	1.42	1.20	0.48	1.05	1.5	1.36
820N	82	418.5	494.0		219.4	0.45	0.63		0.95	0.45	0.95		1.20
101N	100	520.0	683.0	304	247.0	0.40	0.56	1.25	0.90	0.40	0.85	1.35	1.09
121N	120		754.0		298.4		0.53		0.85		0.76		1.00
151N	150		871.0	506	355.1		0.51	0.85	0.80		0.70	1.15	0.91
181N	180				393.4				0.75				0.84
221N	220			756	483.8			0.70	0.70			0.92	0.75
271N	270				632.5				0.60				0.68
331N	330			1090	780.0			0.52	0.50			0.70	0.60
391N	390				957.5				0.45				0.57
471N	470				1220.4				0.42				0.50
561N	560				1352.4				0.39				0.47
681N	680				1519.2				0.36				0.43
821N	820				1694.4				0.34				0.39
102N	1000				1946.4				0.32				0.35

Notes:

Measuring Frequency : 100kHz 0.1V

Tolerance of Inductance : N $\pm$ 30%



## REEL DIMENSIONS :

Unit: mm

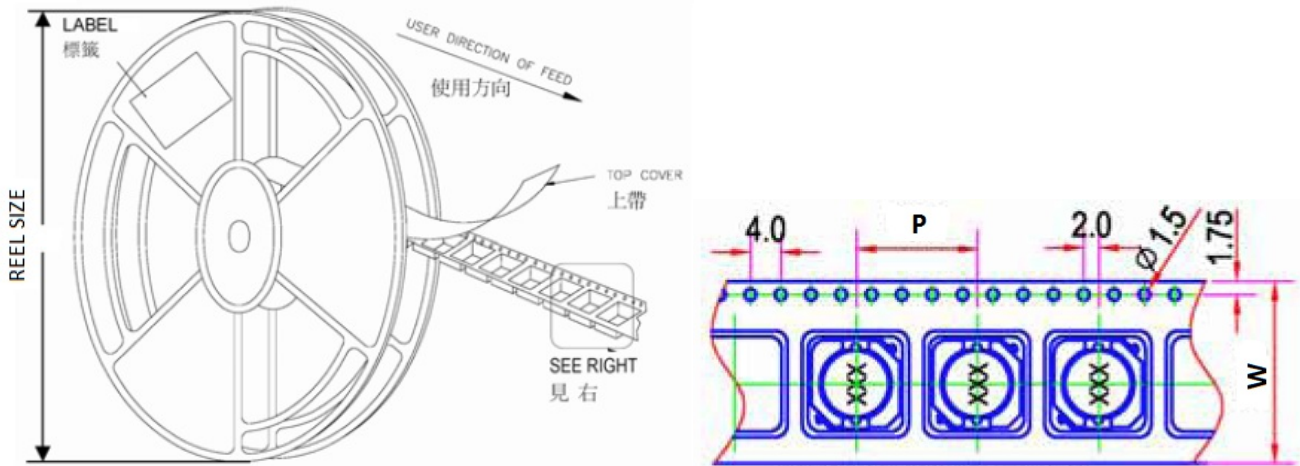

## REEL PACKAGING QUANTITY

TYPE	W	P	REEL SIZE	PCS / REEL
SDRH5D28R	12	8	330 mm (13")	2000
SDRH103R	24	16	330 mm (13")	1000
SDRH104R	24	16	330 mm (13")	750
SDRH105R	24	16	330 mm (13")	750



## RELIABILITY AND TEST CONDITION

### Environmental tests conditions (SMD wire wound Inductor)

Item (項目)	Required Characteristics (要求)	Test Method/Condition (測試方法)
<p>High temperature Storage test</p> <p>Reference documents: MIL-STD-202G Method 108A</p> <p>高溫儲存試驗</p>	<p>1.No case deformation or change in appearance. 2.<math>\Delta L/L \leq 10\%</math> or 15% 3.<math>\Delta DCR/DCR \leq 10\%</math></p> <p>N : The High temperature, depend on the spec. N : 高溫設定，依據產品規格設定</p> <p>1.無明顯的外觀缺陷 2.感值變化不超過 10% 或者 15% 3.直流電阻變化不超過 10%</p>	<p>Temperature: <math>N \pm 2^\circ\text{C}</math> Time : <math>96 \pm 2</math> hours Tested not less than 1 hour, nor more than 2 hours at room temperature.</p> <p>溫度: <math>N \pm 2^\circ\text{C}</math>, 時間: <math>96 \pm 2</math>, 小時 樣品在室溫下放置 1 小時, 不超過 2 小時必須測試.</p>
<p>Low temperature Storage test</p> <p>Reference documents: IEC 68-2-1A 6.1 6.2</p> <p>低溫儲存試驗</p>	<p>1.No case deformation or change in appearance. 2.<math>\Delta L/L \leq 10\%</math> or 15% 3.<math>\Delta DCR/DCR \leq 10\%</math></p> <p>M : The Low temperature, depend on the spec. M : 低溫設定，依據產品規格設定</p> <p>1.無明顯的外觀缺陷 2.感值變化不超過 10% 或者 15% 3.直流電阻變化不超過 10%</p>	<p>Temperature: <math>M \pm 2^\circ\text{C}</math> Time : <math>96 \pm 2</math> hours Tested not less than 1 hour, nor more than 2 hours at room temperature.</p> <p>溫度: <math>M \pm 2^\circ\text{C}</math>, 時間: <math>96 \pm 2</math>, 小時 樣品在室溫下放置 1 小時, 不超過 2 小時必須測試.</p>
<p>Humidity test Reference</p> <p>documents: MIL-STD-202G Method 103B</p> <p>濕度測試</p>	<p>1.No case deformation or change in appearance. 2.<math>\Delta L/L \leq 10\%</math> or 15% 3.<math>\Delta DCR/DCR \leq 10\%</math></p> <p>1.無明顯的外觀缺陷 2.感值變化不超過 10% 或者 15% 3.直流電阻變化不超過 10%</p>	<p>Temperature: <math>40 \pm 2^\circ\text{C}</math> , Humidity: <math>93 \pm 3\% \text{RH}</math> Time : <math>96 \pm 2</math> hours Tested not less than 1 hour, nor more than 2 hours at room temperature.</p> <p>溫度: <math>40 \pm 2^\circ\text{C}</math> , 濕度: <math>93 \pm 3\% \text{RH}</math> 時間 : <math>96 \pm 2</math> hours 樣品在室溫下放置 1 小時, 不超過 2 小時必須測試.</p>
<p>Thermal shock test</p> <p>Reference documents: MIL-STD-202G Method 107G</p> <p>熱衝擊測試</p>	<p>1.No case deformation or change in appearance. 2.<math>\Delta L/L \leq 10\%</math> or 15% 3.<math>\Delta DCR/DCR \leq 10\%</math></p> <p>N : The High temperature, depend on the spec. M : The Low temperature, depend on the spec.</p> <p>For T: weight <math>\leq 28\text{g}</math> : 15Min; <math>28\text{g} \leq \text{weight} \leq 136\text{g}</math> : 30Min</p> <p>1.無明顯的外觀缺陷 2.感值變化小於 10% 或者 15% 3.直流電阻變化小於 10%</p>	<p>First <math>M^\circ\text{C}</math> for T time, next <math>N^\circ\text{C}</math> for T time as 1 cycle. Go through 20 cycles.</p> <p>從 <math>M^\circ\text{C}</math> 作用 T 分鐘, 然後溫度衝擊到 <math>N^\circ\text{C}</math> 作用 T 分鐘, 作為一個循環, 共作用 20 次.</p>

Physical characteristic tests conditions (SMD wire wound Inductor)

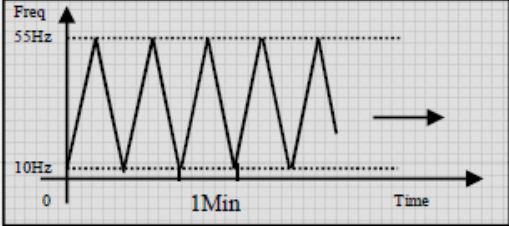
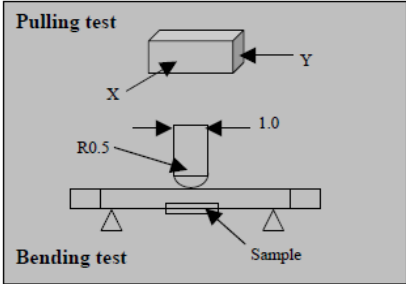
Item (項目)	Required Characteristics (要求)	Test Method/Condition (測試方法)
Solderability test Reference documents: MIL-STD-202G Method 208H IPC J-STD-002B 可焊性測試	Terminals area must have 95% min. Solder coverage 端子必須有 95%以上著錫	<ul style="list-style-type: none"> <li>● Dip pads in flux then dip in solder pot at 245±5°C for 5 second.</li> <li>● Solder: lead free</li> <li>● Flux: rosin flux</li> <li>● 端子侵入著焊劑，然後侵入 245±5°C 錫爐中 5 秒</li> <li>● 焊料：無鉛焊料</li> <li>● 助焊劑：松香助焊劑</li> </ul>
Heat endurance of Reflow soldering Reference documents: IPC J-STD-020D 過再流焊測試	<ul style="list-style-type: none"> <li>● No case deformation or change in appearance.</li> <li>● <math>\Delta L/L \leq 10\%</math> or 15%</li> <li>● <math>\Delta DCR/DCR \leq 10\%</math></li> <li>● 無明顯的外觀缺陷</li> <li>● 感值變化不超過 10% 或者 15%</li> <li>● 直流電阻變化不超過 10%</li> </ul>	<ul style="list-style-type: none"> <li>● Refer to the next page reflow curve Go through 3 times</li> <li>● The peak temperature : 260+/-5°C</li> <li>● 參照下頁回流焊曲線過三次</li> <li>● 峰值溫度為: 260+/-5°C</li> </ul>
Vibration test Reference documents: MIL-STD-202G Method 201A 振動測試	1.No case deformation or change in appearance. 2.No short and no open. 1.無明顯的外觀缺陷 2.無短路開路異常	Apply frequency 10~55Hz. 1.5mm amplitude in each of perpendicular direction for 2 hours.(total 6 hours)  用 10~55Hz 振動頻率 1.5mm 振幅沿 X,Y,Z 方向各振動 2 小時.(共 6 小時)
Drop test Reference documents: MIL-STD-202G Method 203C 落下試驗	1.No case deformation or change in appearance. 2.No short and no open. 1.無明顯的外觀缺陷 2.無短路開路異常	Packaged & Drop down from 1m with 981m/s <sup>2</sup> (100G) attitude In 1 angle 1 ridges & 2 surfaces orientations. 將產品包裝後從 1 米高度自然落下至試驗板上 1 角 1 稜 2 面
Terminal strength push test Reference documents: JIS C 5321:1997 端子強度試驗	Pulling test: DEFINE: A: sectional area of terminal $0.5\text{mm}^2 < A \leq 1.2\text{mm}^2$ ; force >2kgf ; time : 10sec $1.2\text{mm}^2 < A$ ; force >4kgf ; time: 10sec Bending test: Soldering the products on PCB, after the pulling test and bending test ,terminal should not pull off 推力測試 定義: A: 焊接端子截面積 $0.5\text{mm}^2 < A \leq 1.2\text{mm}^2$ ; 推力 >2kgf ; 時間: 10sec $1.2\text{mm}^2 < A$ ; 推力 >4kgf ; 時間: 10sec 彎折測試: 將產品焊於PCB上,分別經過推力測試和彎折測試後,端子不會發生松脫	Bend the testing PCB at middle point, the deflection shall be 2mm  將 PCB 對中彎折,到達撓度 2mm
Resistance to solvent test Reference documents: IEC 68-2-45:1993 耐溶劑性試驗	No case deformation or change in appearance, or obliteration of marking 無外觀破壞及標記破損	To dip parts into IPA solvent for 5±0.5Min, then drying them at room temp for 5Min,at last ,to brushing making 10 times. 在 IPA 溶劑中浸泡 5±0.5 分鐘,室溫下乾燥 5 分鐘,然後擦拭 10 次。



## RELIABILITY TEST CONDITIONS WIRE WOUND CHIP INDUCTORS TYPE

Item (項目)	Required Characteristics(要求)	Test Method / Condition (測試方法)
Electronic characteristic test of major products 主要產品電特性測試	Refer to catalogue of specific products 參照具體產品目錄頁	Refer to catalogue of specific products 參照具體產品目錄頁書
Overload test Reference documents: JIS C5311-6.13 過負荷試驗	<ul style="list-style-type: none"> <li>● During the test no smoke, no peculiar, smell, no fire</li> <li>● The characteristic is normal after test</li> <li>● 試驗過程中無冒煙,異味,著火等,</li> <li>● 試驗後產品特性正常</li> </ul>	Apply twice as rated current for 5 minutes. (It's not application to some special design)  通兩倍額定電流 5 分鐘 (部分特殊設計產品不適用)

### Curve of Heat endurance of Reflow soldering test

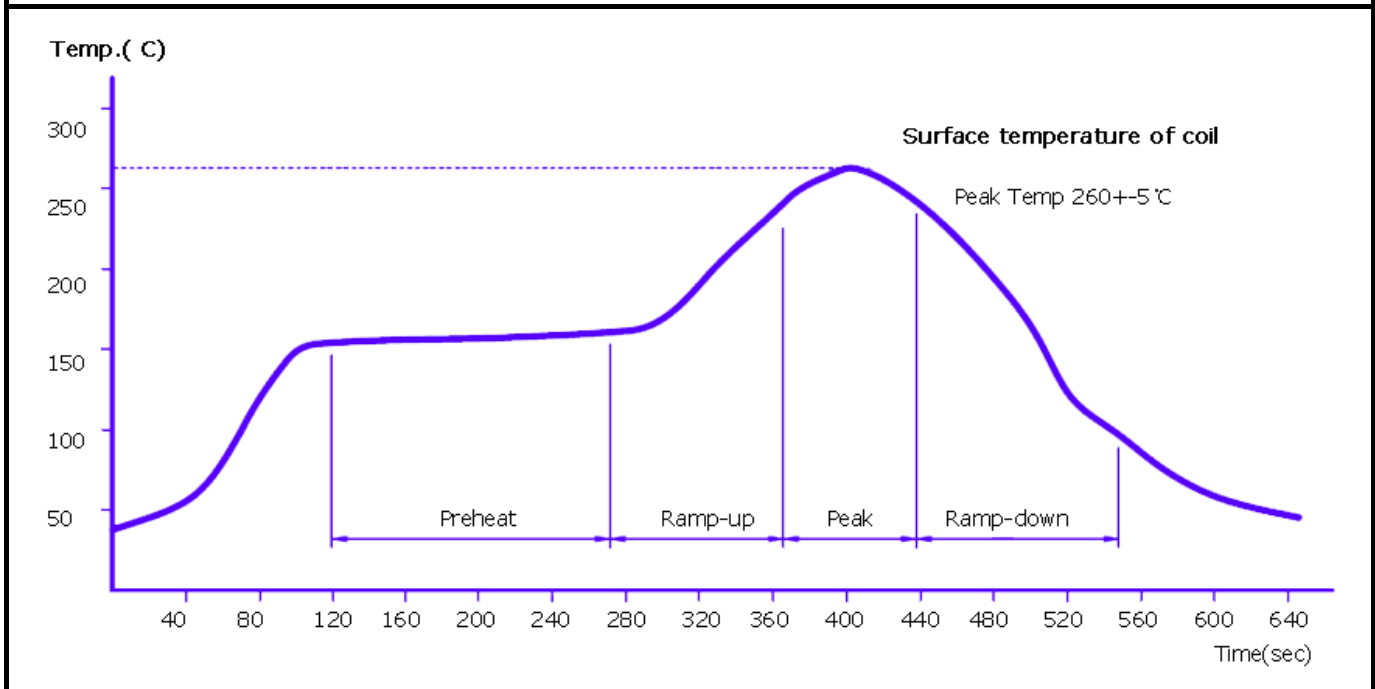

1. This peak temperature only applicable to some special parts. The operating parameter may very according to the part type.
2. A test is made under the conditions mentioned above. And it is left 1 hour in the normal temperature and humidity. After that, no mechanical and electrical defeat should be found out.
3. The reflow condition is according to the machine used by our company.

NOTE : Above specifications are only for reference, follow confirmation documents for the specific test conditions.