



INDEX

SHAPES AND DIMENSIONS..... 1

PART NUMBER CODE 2

ELECTRICAL CHARACTERISTICS 3

REEL DIMENSIONS AND PACKAGING QUANTITY 4



SMT Power Inductor SIE2966410-S1 Series

■ SHAPES AND DIMENSIONS

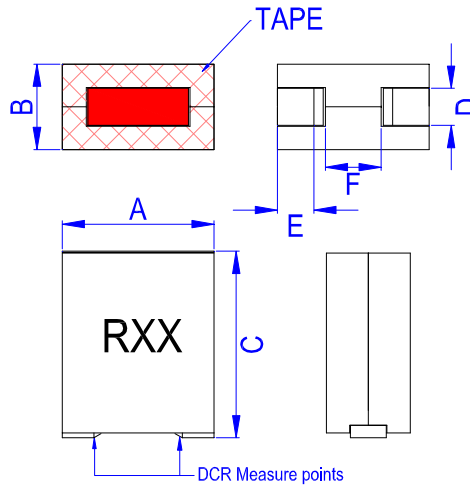

Unit: mm

P/N	A max	B max	C max	D ref	E ref	F ref
SIE2966410-S1	9.6	By each	10.0	2.4	3.15	3.85

Marking : XXX = Inductance

Recommend PAD Layout

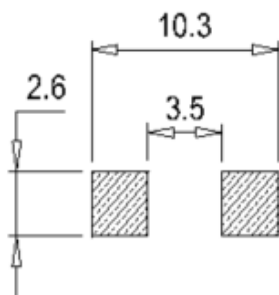

Equivalent circuit

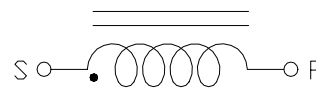



■ PART NUMBER CODE

SIE2 966410 - R10 L A - S1
1 2 3 4 5 6

1. Series Name
2. Size Code
3. Inductance(R=Decimal Point) Unit : μH ; R10 =0.10uH
4. Inductance tolerance: "L" $\pm 15\%$; "M" $\pm 20\%$
5. Soldering : A=Lead Free
6. Special code.



■ ELECTRICAL CHARACTERISTICS

1. Part Number and Characteristics Table

Part number	Initial Inductance (nH)	Tolerance (±%)	DCR (mΩ)	1-Saturation Current @25°C (Amps)(typ)	2-Saturation Current @100°C (Amps)(typ)	Temperature Rise Current (Amps)(typ)	Dim B (mm)
SIE2966410-R07LA-S1	70	15	0.125±10%	110	95	80	6.4±0.2
SIE2966410-R10LA-S1	100	15	0.125±10%	100	89	80	6.4 Max
SIE2966410-R12LA-S1	120	15	0.125±10%	90	80	80	6.4 Max
SIE2966410-R15LA-S1	150	15	0.125±10%	80	70	80	6.4 Max

Note:

- Initial Inductance: Testing at 100 KHz / 1.0 Vrms.
- Saturation Current: DC current that will cause initial Inductance to drop approximately 20%.
- Temperature Rise Current: DC current that will cause an approximate ΔT of 40°C.
- All test data is referenced to 25°C ambient.
- Operating temperature : -40~+125°C (Including self - temperature rise).



■ REEL DIMENSIONS AND PACKAGING QUANTITY

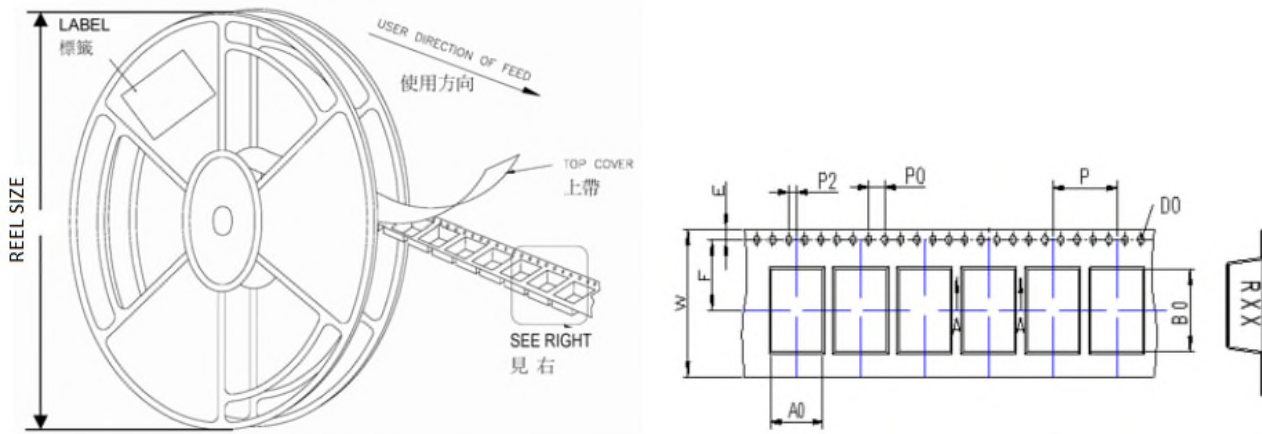

Unit: mm

TYPE	W	P	REEL SIZE	PCS / REEL
SIE2966410-S1	24	16	330 mm (13")	400