



# INDEX

SHAPES AND DIMENSIONS..... 1

PART NUMBER CODE ..... 2

ELECTRICAL CHARACTERISTICS ..... 3

REEL DIMENSIONS AND PACKAGING QUANTITY ..... 4



## SMT Power Inductor SIC060606-R23 series

### ■ SHAPES AND DIMENSIONS

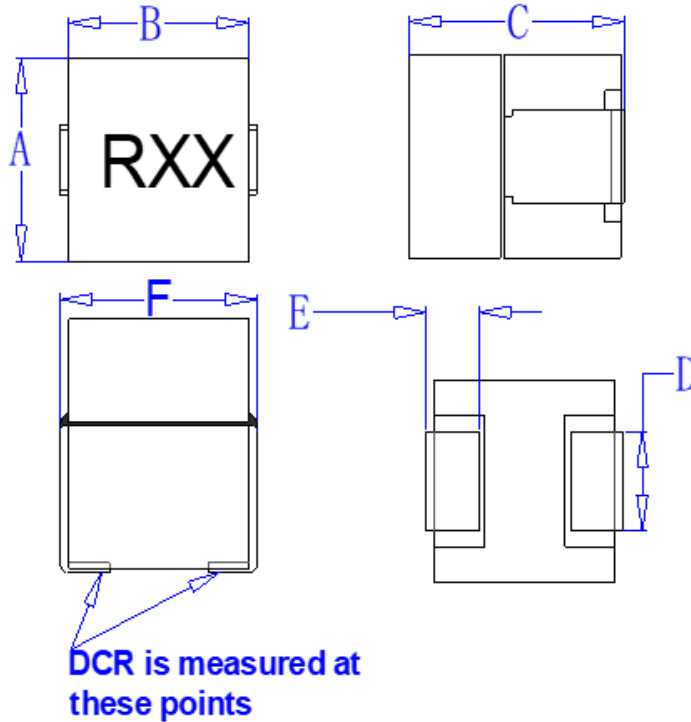

Unit: mm

P/N	A	B	C	D	E	F
SIC060606-R23	5.7 ± 0.5	5.7 ± 0.5	6.3 ± 0.5	3.0 ± 0.2	1.7 ± 0.5	7.0 ± 0.5

Marking : XXX = Inductance

Recommend PAD Layout

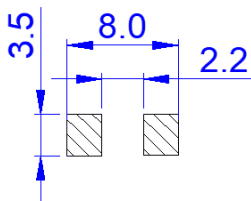

Equivalent circuit

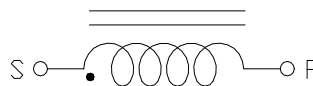



## ■ PART NUMBER CODE

**SIC**   **060606**   -   **R10**   **M**   **A**   -   **R23**  
**1**        **2**                    **3**    **4**    **5**                    **6**

1. Series Name
2. Size Code
3. Inductance(R=Decimal Point) Unit : nH ; R10 = 0.1uH = 100nH
4. Inductance tolerance: "M"±20%.
5. Soldering : A=Lead Free
6. Special code



## ■ ELECTRICAL CHARACTERISTICS

### 1. Part Number and Characteristics Table

Part number	Initial Inductance (nH)	Tolerance (±%)	DCR (mΩ)	1-Saturation Current @25°C (Amps)(typ)	Temperature Rise Current (Amps)(typ)
SIC060606-R10MA-R23	100.0	20	0.23± 7%	40	35
SIC060606-R20MA-R23	200.0	20	0.23± 7%	18	35
SIC060606-R23MA-R23	230.0	20	0.23± 7%	14	35
SIC060606-R33MA-R23	330.0	20	0.23± 7%	5	35

Note:

- Initial Inductance: Testing at 100 KHz / 1.0 Vrms.
- Saturation Current: DC current that will cause initial Inductance to drop approximately 20%.
- Temperature Rise Current: DC current that will cause an approximate ΔT of 40°C.
- All test data is referenced to 25°C ambient.
- Operating temperature : -40~+125°C (Including self - temperature rise).



## ■ REEL DIMENSIONS AND PACKAGING QUANTITY

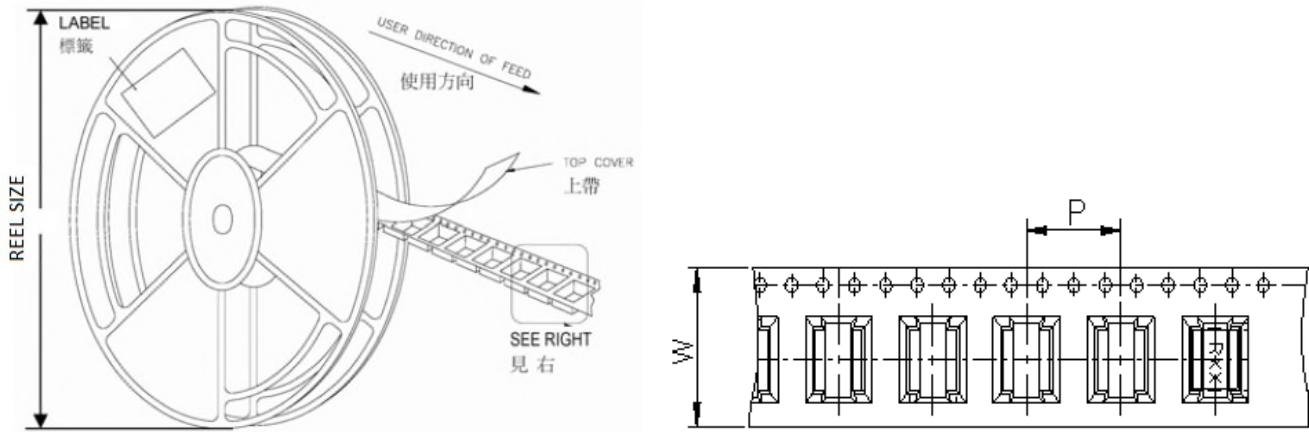

Unit: mm

TYPE	W	P	REEL SIZE	PCS / REEL
SIC060606-R23	16	12	330 mm (13")	700