



INDEX

REVISION CHANGE RECORD.....	1
SHAPES AND DIMENSIONS.....	2
PART NUMBER CODE	2
PART NUMBER AND CHARACTERISTICS TABLE	3
TYPICAL PERFORMANCE CURVES.....	4
REEL DIMENSIONS AND PACKAGING QUANTITY	7
RECOMMENDED SOLDERING CONDITIONS	8
RELIABILITY AND TEST CONDITION.....	9
NOTE	10



■ REVISION CHANGE RECORD

REV	ISSUE OF NEW SPECIFICATION	DATE OF ISSUE
AAM	Initial Release.	2023/08/22



■ SHAPES AND DIMENSIONS

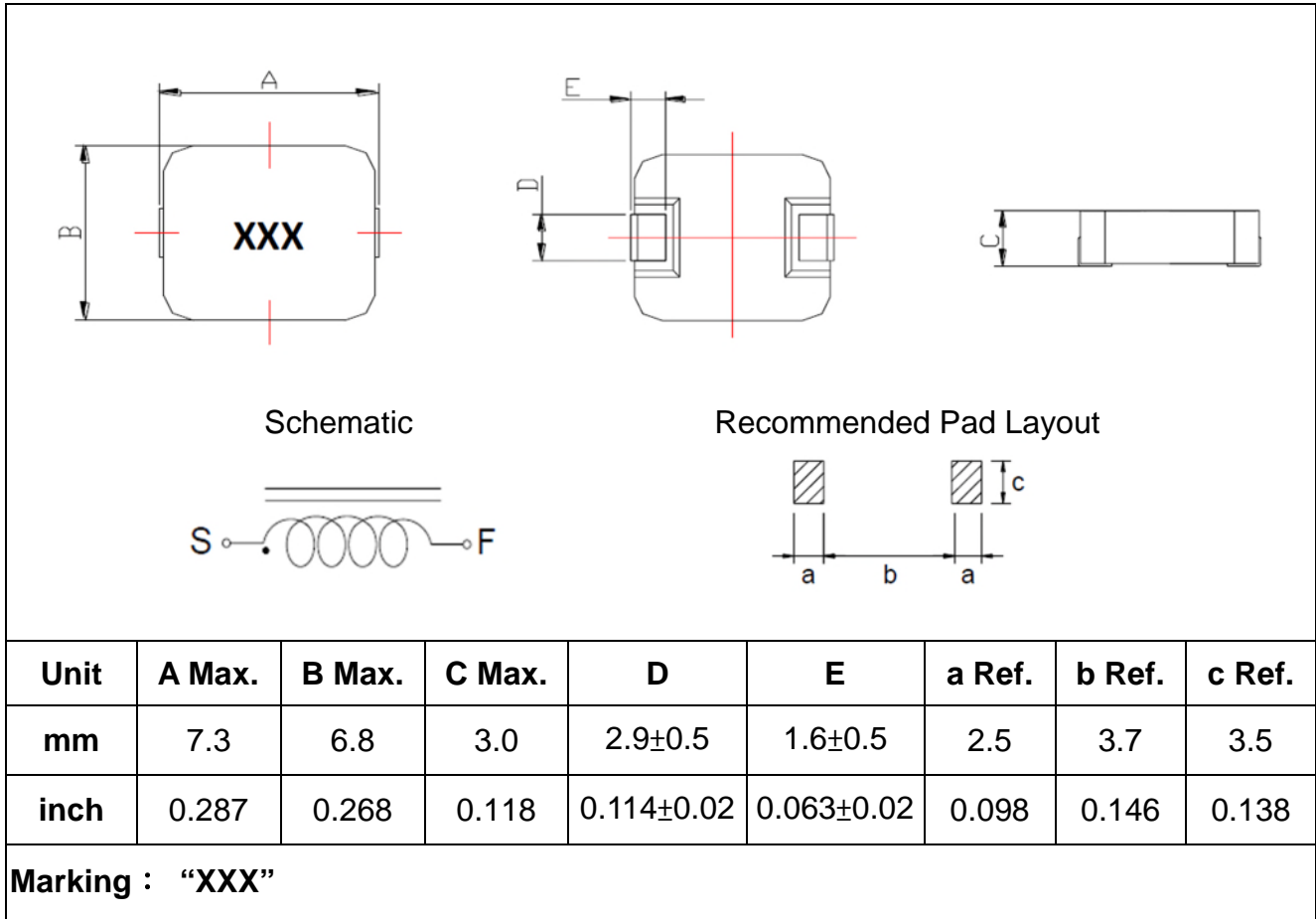

■ PART NUMBER CODE

SPI 0603 N S - R10 M A
 1 2 3 4 5 6 7

1. Series Name
2. Size code
3. Material code
4. Special code
5. Inductance (R=Decimal Point) Unit : uH; R10=0.1uH
6. Inductance tolerance : "M"±20%.
7. Soldering : A=Lead Free



■ PART NUMBER AND CHARACTERISTICS TABLE

Part Number	Initial Inductance (uH)	Tolerance (±%)	DCR (mΩ) Max.	Temperature Rise Current (Amps)	Saturation Current (Amps)
SPI0603NS-R10MA	0.10	20	1.7	37.0	45.0
SPI0603NS-R22MA	0.22	20	2.8	23.0	40.0
SPI0603NS-R33MA	0.33	20	3.5	21.0	25.0
SPI0603NS-R47MA	0.47	20	4.1	18.0	20.0
SPI0603NS-R56MA	0.56	20	4.5	16.5	18.0
SPI0603NS-R68MA	0.68	20	5.3	16.0	17.0
SPI0603NS-R82MA	0.82	20	6.0	14.0	16.0
SPI0603NS-1R0MA	1.00	20	7.4	12.0	15.0
SPI0603NS-1R2MA	1.20	20	7.4	12.0	14.5
SPI0603NS-1R5MA	1.50	20	10.0	10.0	14.0
SPI0603NS-2R2MA	2.20	20	15.0	8.0	10.0
SPI0603NS-3R3MA	3.30	20	22.0	6.5	9.5
SPI0603NS-4R7MA	4.70	20	33.0	5.5	6.5
SPI0603NS-5R6MA	5.60	20	42.0	5.5	6.0
SPI0603NS-6R8MA	6.80	20	50.0	4.5	6.0
SPI0603NS-8R2MA	8.20	20	60.0	4.3	5.8
SPI0603NS-100MA	10.00	20	68.0	4.0	5.5
SPI0603NS-150MA	15.00	20	150.0	3.0	4.0
SPI0603NS-220MA	22.00	20	210.0	2.5	3.0

Note:

1. Operating temperature: - 55°C to +125°C
2. Initial Inductance: Testing at 100KHz/ 0.25Vrms
3. Saturation Current: DC current that will cause initial Inductance to drop approximately 30%.
4. Heating Current: DC current that will cause an approximate ΔT of 40°C.
5. All test data is referenced to 25°C ambient.

■ TYPICAL PERFORMANCE CURVES

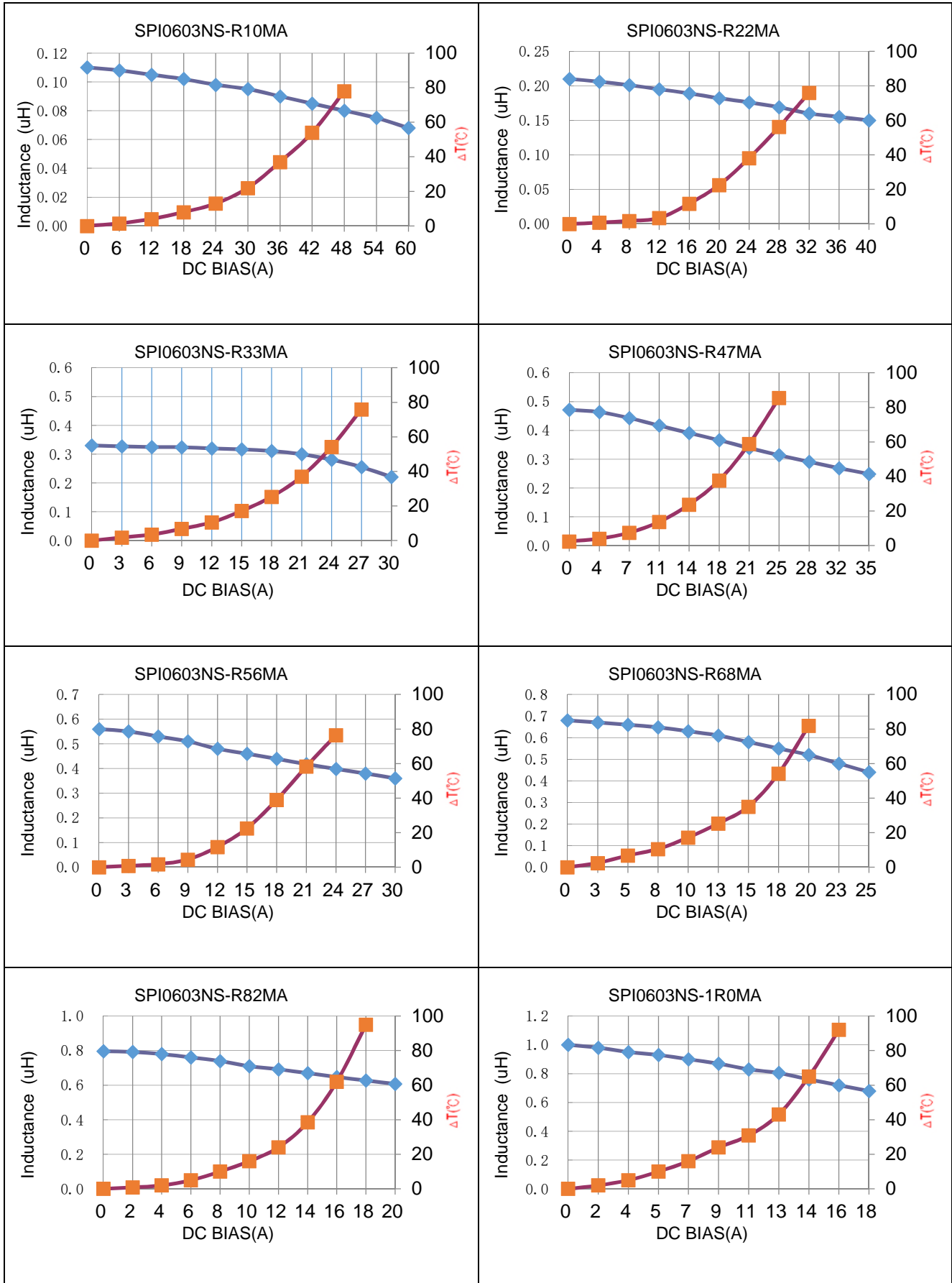

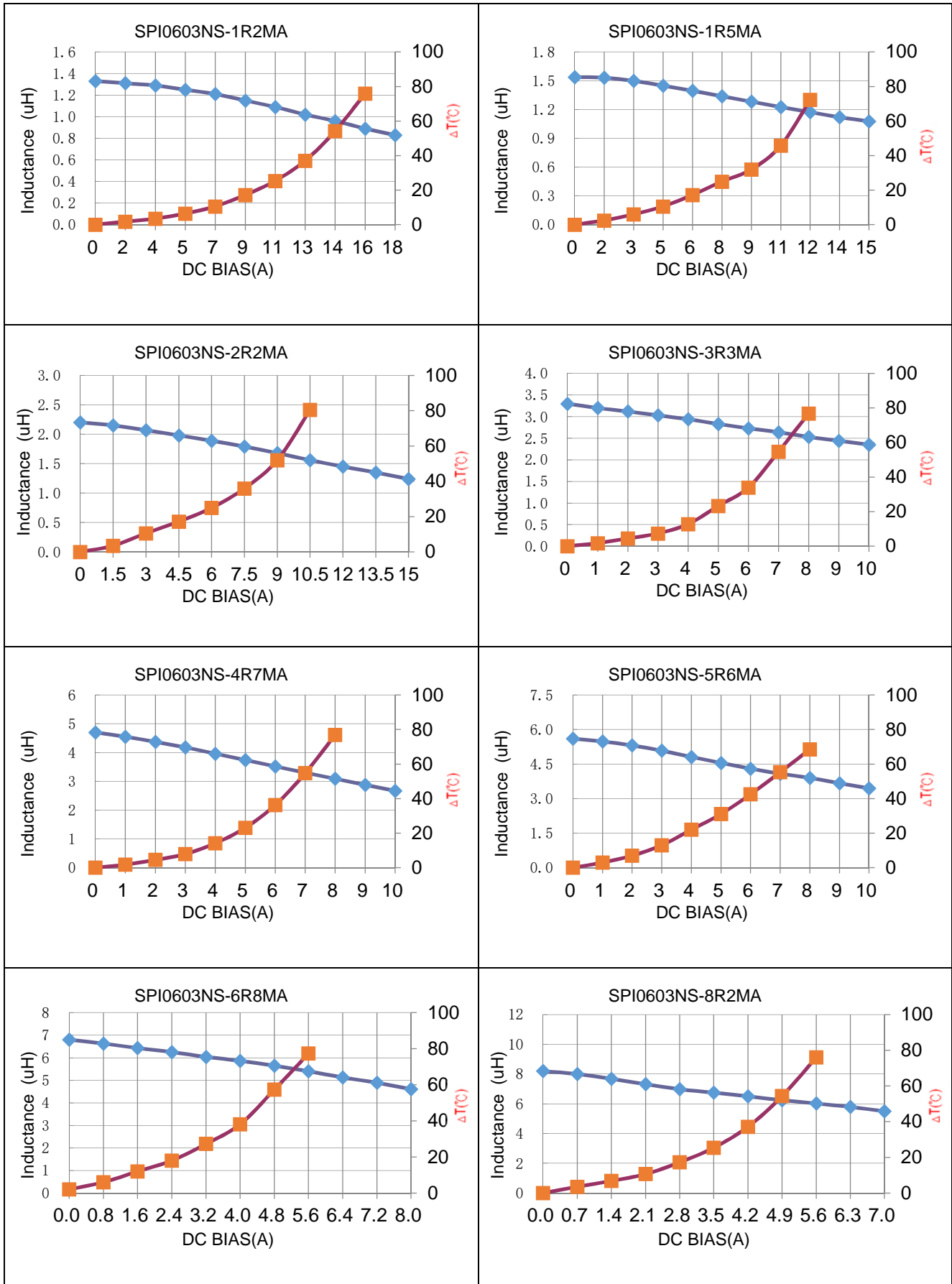

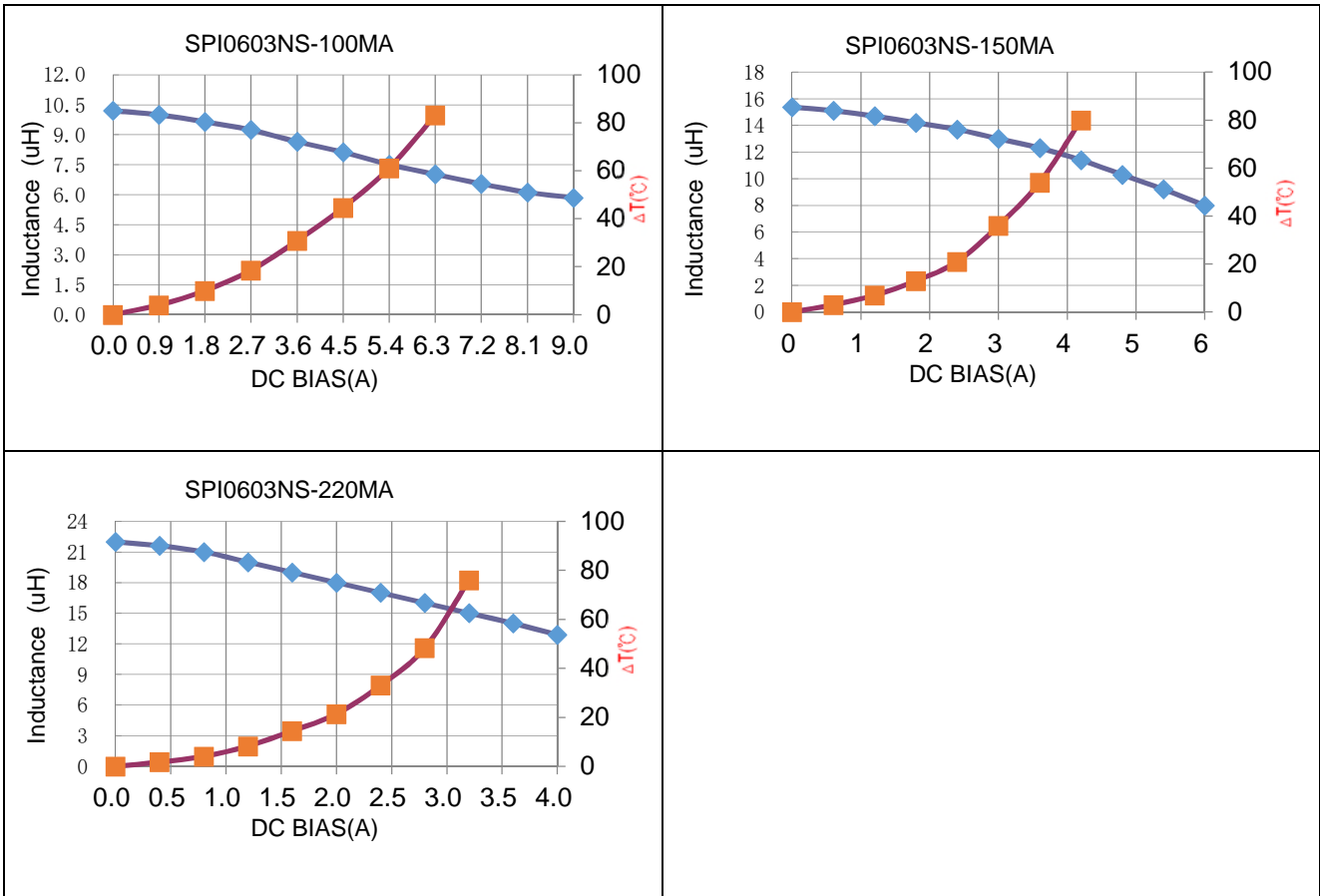



REEL DIMENSIONS AND PACKAGING QUANTITY

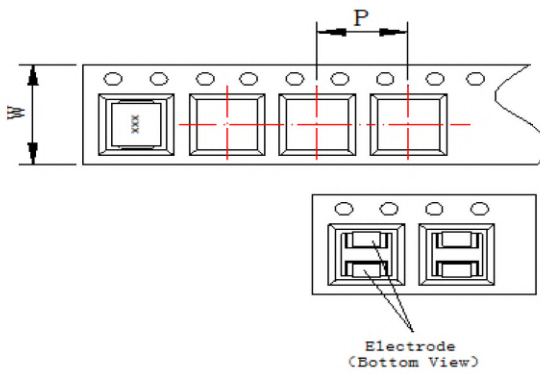
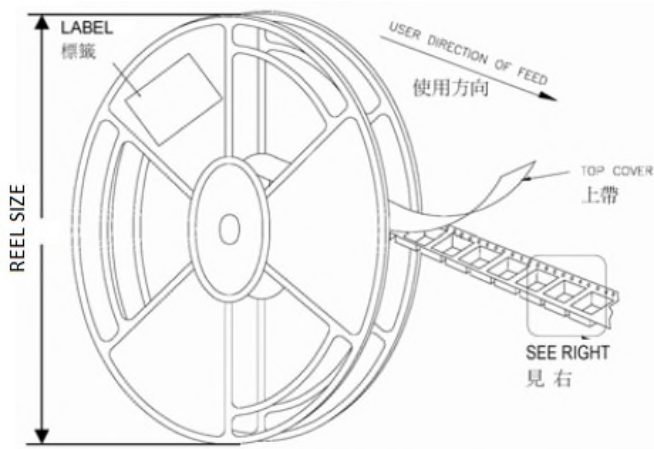

Unit: mm

TYPE	W	P	REEL SIZE	PCS / REEL
SPI0603NS Series	16	12	330 mm(13")	1500



RECOMMENDED SOLDERING CONDITIONS

1. Re-flow Soldering

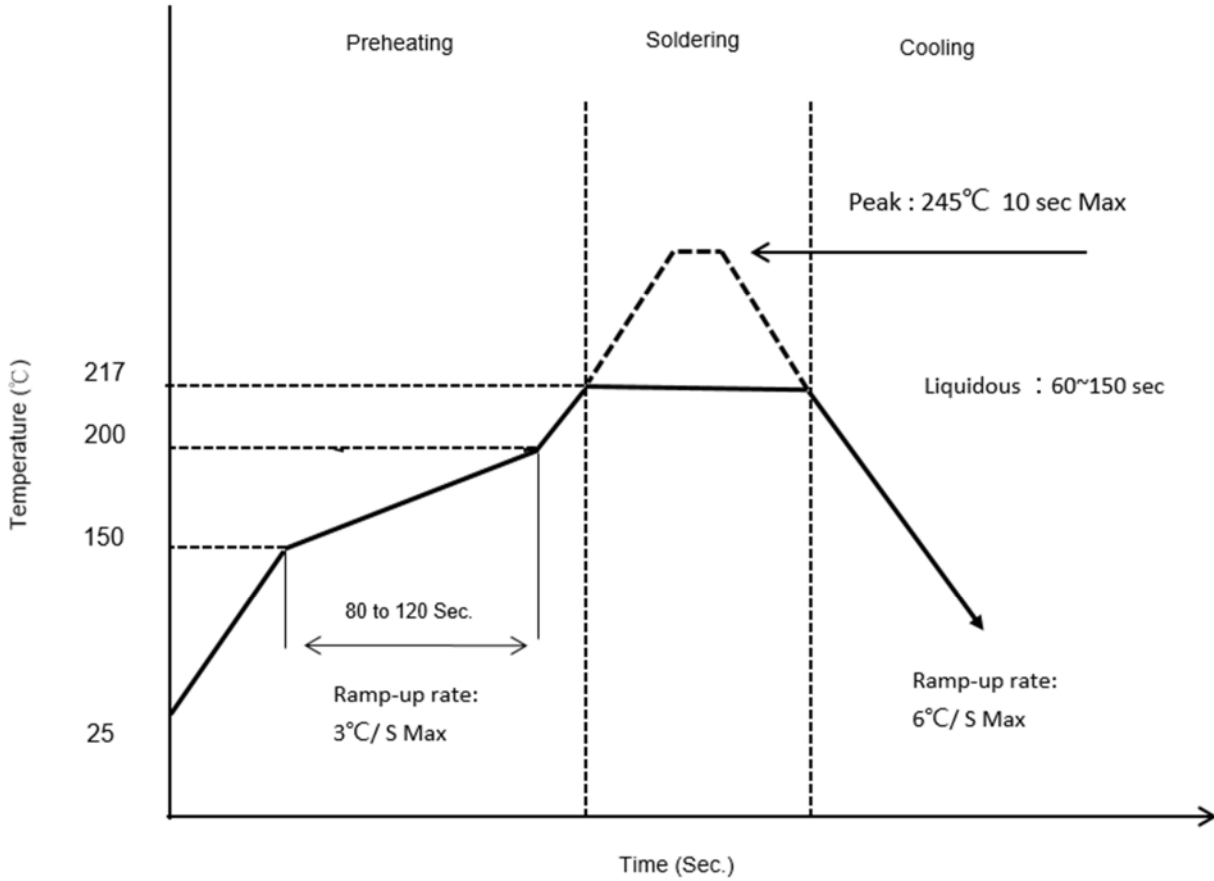



■ RELIABILITY AND TEST CONDITION

ITEM	SPECIFICATION	CONDITION															
Resistance to Soldering Heat	More than 95% of the terminal electrode should be covered with solder.																
Solderability	Inductance within $\pm 20\%$ of initial value. No disconnection or short circuit. The appearance shall not break.																
Heat Resistance	Inductance within $\pm 20\%$ of initial value. No disconnection or short circuit. The appearance shall not break.	After 1000 hours in $125\pm 5^\circ\text{C}$ and 1 hour drying under normal condition.															
Cold Resistance	Inductance within $\pm 20\%$ of initial value. No disconnection or short circuit. The appearance shall not break.	After 1000 hours in $-40\pm 2^\circ\text{C}$ and 1 hour drying under normal condition.															
Thermal Shock	Inductance within $\pm 20\%$ of initial value. No disconnection or short circuit. The appearance shall not break.	After 100 cycles <table border="1" style="margin-left: 20px;"> <thead> <tr> <th>Step</th> <th>Temperature ($^\circ\text{C}$)</th> <th>Times (min.)</th> </tr> </thead> <tbody> <tr> <td>1</td> <td>$-40\pm 2^\circ\text{C}$</td> <td>30</td> </tr> <tr> <td>2</td> <td>Room Temperature</td> <td>Within 3</td> </tr> <tr> <td>3</td> <td>$125\pm 5^\circ\text{C}$</td> <td>30</td> </tr> <tr> <td>4</td> <td>Room Temperature</td> <td>Within 3</td> </tr> </tbody> </table>	Step	Temperature ($^\circ\text{C}$)	Times (min.)	1	$-40\pm 2^\circ\text{C}$	30	2	Room Temperature	Within 3	3	$125\pm 5^\circ\text{C}$	30	4	Room Temperature	Within 3
Step	Temperature ($^\circ\text{C}$)	Times (min.)															
1	$-40\pm 2^\circ\text{C}$	30															
2	Room Temperature	Within 3															
3	$125\pm 5^\circ\text{C}$	30															
4	Room Temperature	Within 3															
Humidity Resistance	Inductance within $\pm 20\%$ of initial value. No disconnection or short circuit. The appearance shall not break.	After 1000 hours in $85^\circ\text{C}/85\%\text{RH}$. Measurement at 24 ± 2 hours after test conclusion.															
Vibration Test	Inductance within $\pm 20\%$ of initial value and appearance shall not break.	1. Reflow: 2times 2. Frequency: $10\text{HZ}\sim 55\text{HZ}\sim 10\text{HZ}$, 20 Min/Cycles 3. Amplitude: 1.52 mm 4. Directions: X, Y, Z 5. Time: 12 cycle / direction.															



■ NOTE

1. Storage condition:

To maintain the solderability of terminal electrodes:

- 1.1. Temperature and humidity conditions: 5~35°C and 35~70%RH.
- 1.2. Storage life: 12 months Max. If product is preserved for more than 1 year, the solderability of their terminals may be deteriorated.
- 1.3. The packaging material should be kept where no chlorine or corrosive gas environment. (example: salt, sulfur, acid, etc ..)

2. Transportation

- 2.1. Products should be handled with care to avoid damage or contamination from perspiration and skin oils.
- 2.2. The use of tweezers or vacuum pick up is strongly recommended for individual components.
- 2.3. Bulk handling should ensure that abrasion and mechanical shock are minimized.

3. Application

The products listed on this datasheet are intended for use in general electronic equipment under a normal operation and use condition.

The products are not designed or warranted to meet the requirements of the applications listed below, whose performance and/or quality require a more stringent level of safety or reliability, or whose failure, malfunction or trouble could cause serious damage to society, person or property. ETC shall not be held liable for any malfunction or breakdown caused by using product in the condition which is inconsistent with that recommended by ETC.

(1)Military equipment. (2)Medical equipment. (3)Aerospace equipment. (4) Other applications that are not considered general-purpose applications.