



INDEX

SHAPES AND DIMENSIONS.....	1
PART NUMBER CODE	1
ELECTRICAL CHARACTERISTICS.....	2
TYPICAL PERFORMANCE CURVES.....	3
REEL DIMENSIONS AND PACKAGING QUANTITY	5
NOTE	6



Shielded SMT Power Inductor SPIM0603BS Series

■ SHAPES AND DIMENSIONS

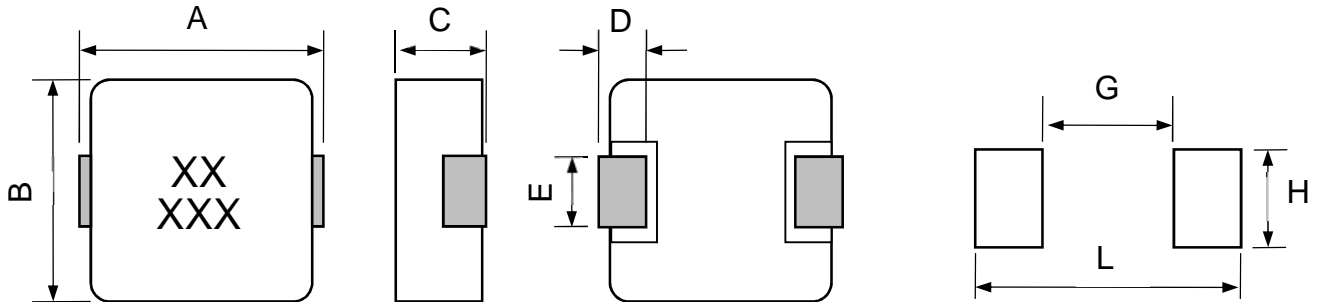

Unit	A Max.	B Max.	C Max.	D	E
mm	7.3	6.8	3.0	1.6 ± 0.3	3.0 ± 0.5
inch	0.287	0.268	0.118	0.063 ± 0.012	0.118 ± 0.020

Recommend PAD Layout

G Ref.	H Ref.	L Ref.
3.7	3.5	8.0
0.146	0.138	0.315

Marking :

MB
XXX = Inductance

Schematic :

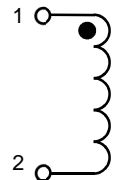

■ PART NUMBER CODE

SPIM **0603** **BS** - **1R0** **M** **A**
1 **2** **3** **4** **5** **6**

1. Series Name
2. Size Code
3. Material Code
4. Inductance(R=Decimal Point) Unit : μH ; 1R0 =1.0uH
5. Inductance tolerance: "M"±20%
6. Soldering : A=Lead Free



■ ELECTRICAL CHARACTERISTICS

1. Test equipments

1.1. L : WK3260B LCR Meter.

1.2. DCR: Chroma 16502 Milli-ohm meter.

1.3. IWT test: Chroma 19301(A).(Impulse winding test)

1.4. Saturation Current (Isat): The DC current will cause L0 to drop approximately 30% typical.

1.5. Temperature Rise Current (Irms): The DC current will cause the coil temperature rise approximately ΔT of 40°C.

1.6. Operating temperature: -55°C to 125°C

* Equivalent measurement equipment may be used.

2. Part Number and Characteristics Table

Part No.	Inductance L ₀ (uH)	DCR (mΩ)		Isat(A)		Irms (A)		E(mm) ±0.5
		Typ.	Max.	Typ.	Max.	Typ.	Max.	
SPIM0603BS-R82MA	0.82	7.1	8.0	26.0	25.0	15.0	14.0	3.0
SPIM0603BS-1R0MA	1.0	9.3	10.0	25.0	22.0	14.0	11.0	3.0
SPIM0603BS-1R2MA	1.2	11.5	13.0	23.0	20.0	12.0	10.0	3.0
SPIM0603BS-1R5MA	1.5	13.5	15.0	22.0	18.0	11.0	9.0	3.0
SPIM0603BS-2R2MA	2.2	18.3	20.0	15.0	14.0	10.0	8.0	3.0
SPIM0603BS-3R3MA	3.3	23.5	30.0	13.5	12	7.5	6.5	3.0
SPIM0603BS-4R7MA	4.7	38.0	40.0	11.0	10.0	6.5	5.5	3.0
SPIM0603BS-6R8MA	6.8	54.8	60.0	9.0	8.0	5.0	4.5	3.0
SPIM0603BS-8R2MA	8.2	61.5	68.0	8.5	7.5	4.5	4.0	3.0
SPIM0603BS-100MA	10.0	102.5	105.0	7.5	7.5	4.0	3.0	3.0
SPIM0603BS-220MA	22.0	132.0	155.0	5.0	3.5	3.3	2.5	3.0

Note 1: Referenced ambient temperature 25°C.

Note 2: Test Condition: 100kHz, 0.25 Vrms.

Note 3: Isat (Typ): DC current (A) that will cause L0 to drop approximately 30%

Isat (Max): DC current (A) that will cause L0 to drop 30% Max

Irms (Typ): DC current (A) that will cause an approximate ΔT of 40°C

Irms (Max): DC current (A) that will cause an ΔT of 40°C Max

Note 4: Operating Temperature range includes self-temperature rise

Note 5: The rated current as listed is either the saturation current or the heating current depending on which value is lower.



■ TYPICAL PERFORMANCE CURVES

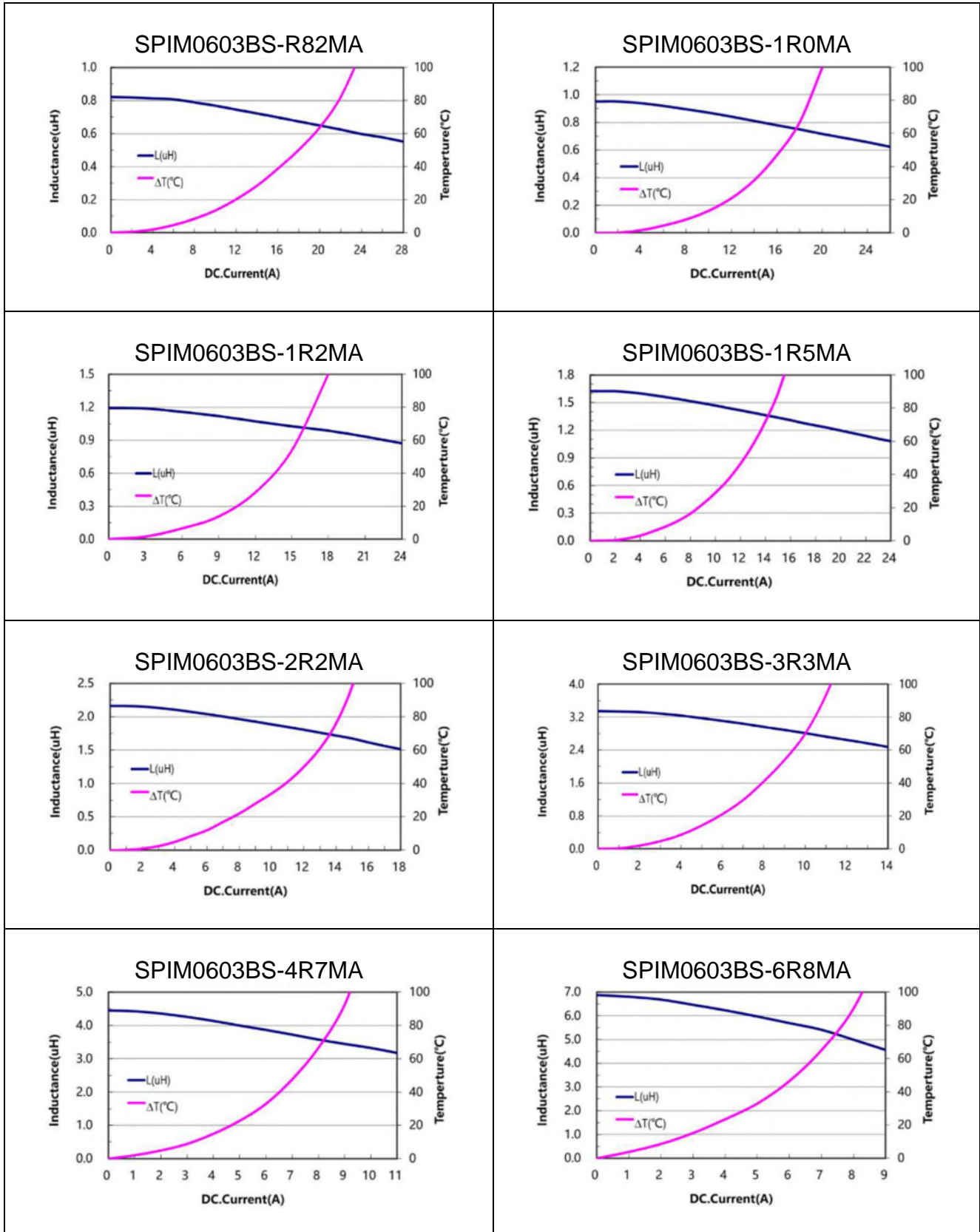

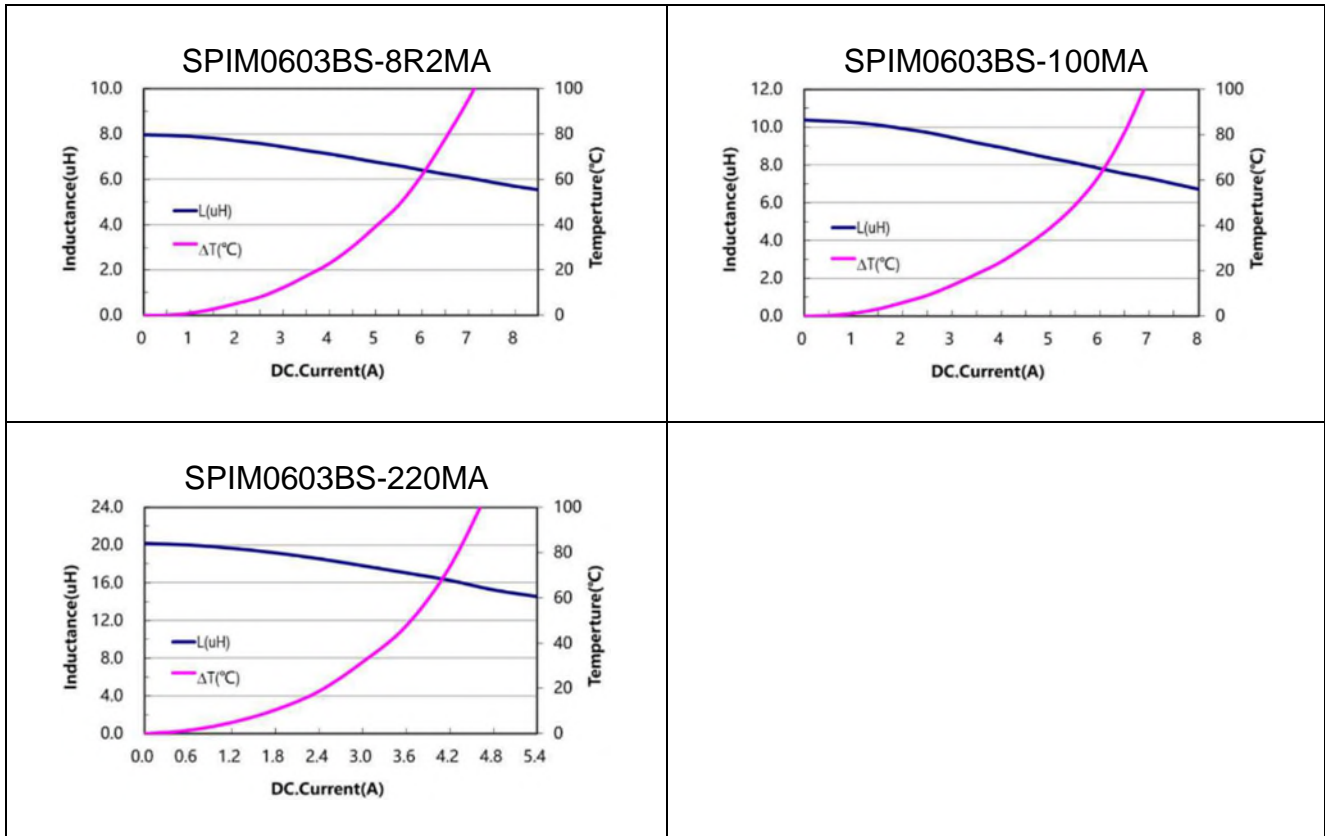



■ REEL DIMENSIONS AND PACKAGING QUANTITY

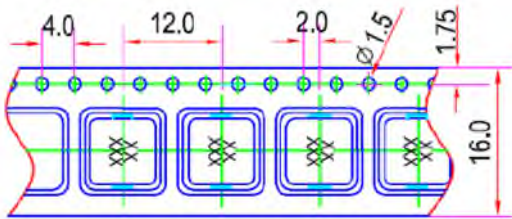
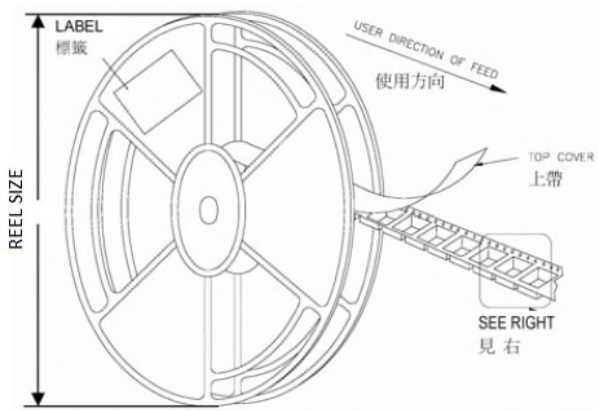

Unit: mm

TYPE	W	P	REEL SIZE	PCS / REEL
SPIM0603BS Series	16	12	330 mm (13")	1500



■ NOTE

1. Storage condition:

To maintain the solderability of terminal electrodes:

- 1.1. Temperature and humidity conditions: 5~35°C and 35~70%RH.
- 1.2. Storage life: 12 months Max. If product is preserved for more than 1 year, the solderability of their terminals may be deteriorated.
- 1.3. The packaging material should be kept where no chlorine or corrosive gas environment. (example: salt, sulfur, acid, etc ..)

2. Transportation

- 2.1. Products should be handled with care to avoid damage or contamination from perspiration and skin oils.
- 2.2. The use of tweezers or vacuum pick up is strongly recommended for individual components.
- 2.3. Bulk handling should ensure that abrasion and mechanical shock are minimized.

3. Application

The products listed on this datasheet are intended for use in general electronic equipment under a normal operation and use condition.

The products are not designed or warranted to meet the requirements of the applications listed below, whose performance and/or quality require a more stringent level of safety or reliability, or whose failure, malfunction or trouble could cause serious damage to society, person or property. ETC shall not be held liable for any malfunction or breakdown caused by using product in the condition which is inconsistent with that recommended by ETC.

(1)Military equipment. (2)Medical equipment. (3)Aerospace equipment. (4) Other applications that are not considered general-purpose applications.